

INSTRUCTION MANUAL

Sound Level Meter

NL-20



3-20-41 Higashimotomachi, Kokubunji, Tokyo 185-8533, Japan

<http://www.rion.co.jp/english/>

Organization of the NL-20 Documentation

The documentation for the Sound Level Meter NL-20 consists of three separate manuals.

- **Instruction Manual (this document)**
Describes operating procedures for the Sound Level Meter NL-20, connection and use of peripheral equipment such as a level recorder and printer.
- **Serial Interface Manual**
Describes how to use the serial interface built into the Sound Level Meter NL-20. The manual covers the communication protocol, use of control commands for the sound level meter, format of data output by the sound level meter, and other topics.
- **Technical Notes**
This document provides in-depth information about the circuit configuration and performance of the sound level meter, microphone construction and characteristics, influence of extension cables and windscreen on the measurement, and other topics.

* Company names and product names mentioned in this manual are usually trademarks or registered trademarks of their respective owners.

Organization of This Manual

This manual describes the features, operation and other aspects of the Sound Level Meter NL-20

The manual contains the following sections.

Outline

Gives basic information about the configuration and features of the unit, and also contains a block diagram.

Controls and Functions

Briefly identifies and explains the controls and connectors and all other parts of the unit.

Preparations

Gives information about power supply, pre-use checks, installation, connections, key settings etc.

Reading the Display

Explains the symbols and other information appearing on the display of the unit.

Power On/Off

Explains how to turn the unit on and off.

Measurement

Explains how to perform measurement.

Store Operations

Explains how to store measurement results in the memory of the unit.

Default Settings

Lists the factory default settings of the unit.

Output Connectors

Explains the output connectors of the unit.

Optional Accessories

Explains how to use external equipment for example to store measurement data.

Specifications

Lists the technical specifications of the unit.

* All company names and product names mentioned in this manual are trademarks or registered trademarks of their respective owners.

To conform to the EU requirement of the Directive 2002/96/EC on Waste Electrical and Electronic Equipment, the symbol mark on the right is shown on the instrument.



FOR SAFETY

In this manual, important safety instructions are specially marked as shown below. To prevent the risk of death or injury to persons and severe damage to the unit or peripheral equipment, make sure that all instructions are fully understood and observed.



Disregarding instructions printed here incurs the risk of injury to persons and/or damage to peripheral equipment.

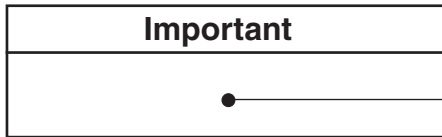

Disregarding instructions printed here incurs the risk of damage to the product.

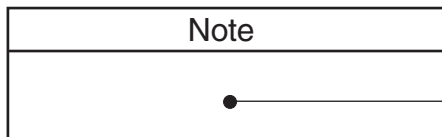

Mentioned about the tips to use this unit properly. (This messages do not have to do with safety.)

Precautions

- Operate the unit only as described in this manual.
- Protect the unit from shocks and vibration. Be especially careful not to touch the microphone membrane to avoid damage. The membrane is an extremely thin metal film which can be damaged easily.
- Do not use the unit with a different microphone/preamplifier from the one indicated on the name plate of the unit.
- Ambient conditions for operation of the unit are as follows: temperature range -10 to +50°C, relative humidity 10 to 90%.
Protect the unit from water, dust, extreme temperatures, humidity, and direct sunlight during storage and use. Also keep the unit away from air with high salt or sulphur content, gases, and stored chemicals.
- Always turn the unit off after use. Remove the batteries from the unit if it is not to be used for a long time. When disconnecting cables, always grasp the plug and do not pull the cable.
- Clean the unit only by wiping it with a soft, dry cloth or, when necessary, with a cloth lightly moistened with water. Do not use any solvents, cleaning alcohol or cleaning agents.
- Do not try to disassemble the unit.
In case of an apparent malfunction, do not attempt any repairs. Note the condition of the unit clearly and contact the supplier.
- Do not tap the LCD panel or other surfaces of the unit with a pointed object such as a pencil, screwdriver, etc.
- Take care that no conductive objects such as wire, metal scraps, conductive plastics etc. can get into the unit.
- To ensure continued precision, have the unit checked and serviced at regular intervals.
- When disposing of the unit, be sure to observe all applicable legal regulations and guidelines in your country and community.

Quantifier Notation of Sound Level Meter NL-20 According to International Standards and JIS

(Excerpts from ISO 1996, 3891, IEC 61672-1, JIS Z 8202, 8731)

| NL-20 notation | Description | Frequency weighting | ISO notation | IEC notation | JIS notation |
|----------------|--|---------------------|--------------|--------------|--------------|
| L_p | Sound level | FLAT | L_p | — | L_p |
| L_A | A-weighted sound level | A | L_{pA} | — | L_{pA} |
| L_C | C-weighted sound level | C | — | — | — |
| L_{peq} | Equivalent continuous sound level | FLAT | — | — | — |
| L_{Aeq} | Equivalent continuous A-weighted sound level | A | $L_{Aeq,T}$ | $L_{Aeq,T}$ | $L_{Aeq,T}$ |
| L_{Ceq} | Equivalent continuous C-weighted sound level | C | — | $L_{Ceq,T}$ | — |
| L_{pE} | Sound exposure level | FLAT | — | — | — |
| L_{AE} | A-weighted sound exposure level | A | L_{AE} | $L_{AE,T}$ | L_{AE} |
| L_{CE} | C-weighted sound exposure level | C | — | — | — |
| L_{AN} | Percentile A-weighted sound level | A | $L_{AN,T}$ | — | $L_{AN,T}$ |
| L_{A05} | | | $L_{A5,T}$ | — | $L_{A5,T}$ |
| L_{A10} | | | $L_{A10,T}$ | — | $L_{A10,T}$ |
| L_{A50} | | | $L_{A50,T}$ | — | $L_{A50,T}$ |
| L_{A90} | | | $L_{A90,T}$ | — | $L_{A90,T}$ |
| L_{A95} | $L_{A95,T}$ | — | $L_{A95,T}$ | | |
| L_{Amax} | Maximum A-weighted sound level | A | — | — | — |
| L_{Amin} | Minimum A-weighted sound level | A | — | — | — |
| L_{Cpk} | C-weighted peak sound level | C | — | L_{Cpeak} | — |

Contents

| | |
|--|-----|
| Organization of the NL-20 Documentation | i |
| FOR SAFETY | v |
| Precautions | vii |
| Quantifier Notation of Sound Level Meter NL-20 According to International Standards and JIS | ix |
| Outline | 1 |
| Controls and Functions | 3 |
| Front View | 3 |
| Operation Keys | 4 |
| Bottom View | 7 |
| Rear View | 8 |
| Preparations | 9 |
| Power Supply | 9 |
| Windscreen (WS-10) | 12 |
| Tripod Mounting | 12 |
| Microphone Extension Cables (EC-04 series) | 13 |
| Connection to a Printer (DPU-414, CP-11, CP-10) | 15 |
| Connection to a Level Recorder (LR-06, LR-07, LR-04, LR-20A) | 18 |
| Connection to a Computer | 18 |
| Measurement in Dark Locations | 19 |
| LCD Contrast | 20 |
| Calibration | 21 |
| Reading the Display | 28 |
| Display screen | 28 |
| Menu screens | 32 |

| | |
|--|----|
| Power On/Off..... | 36 |
| Measurement..... | 38 |
| Sound level Measurement | 38 |
| Equivalent Continuous Sound level (L_{Aeq}) Measurement | 41 |
| Sound Exposure Level (L_{AE}) Measurement | 46 |
| Maximum (L_{max}) and Minimum (L_{min}) Sound level Measurement | 51 |
| Percentile Sound level (L_N) Measurement..... | 56 |
| Back-Erase Function | 62 |
| Store Operations | 63 |
| Default Settings..... | 68 |
| Output Connectors | 69 |
| AC Output | 69 |
| DC Output | 70 |
| I/O Connector..... | 71 |
| Optional Accessories..... | 72 |
| Microphone Extension Cables EC-04 Series..... | 72 |
| Printer DPU-414/CP-11/CP-10 | 73 |
| Level Recorder LR-06/LR-07/LR-04/LR-20A | 76 |
| Specifications | 78 |

Outline

The Sound Level Meter NL-20 complies to IEC and JIS standards. In addition to the regular noise and sound level measurements of conventional sound level meters, it also incorporates the following measurement functions.

- Sound level L_p
- Equivalent continuous sound level L_{eq}
- Sound exposure level L_E
- Maximum sound level L_{max}
- Minimum sound level L_{min}
- Percentile sound level L_N (five selectable settings)

Measurement settings and results (level values and bar graph) are shown on the backlit LCD panel.

Measurement data (sound level, processed data, measurement parameters) can be stored in the internal memory of the unit . The serial interface allows sending measurement data to a printer or computer.

The following accessories are optional, to cover a wide range of application requirements.

- Printer DPU-414
Serves to produce hard copy of measurement data (including data stored in memory).
- Level recorder LR-07, LR-20A
Serves to record sound level changes over time.

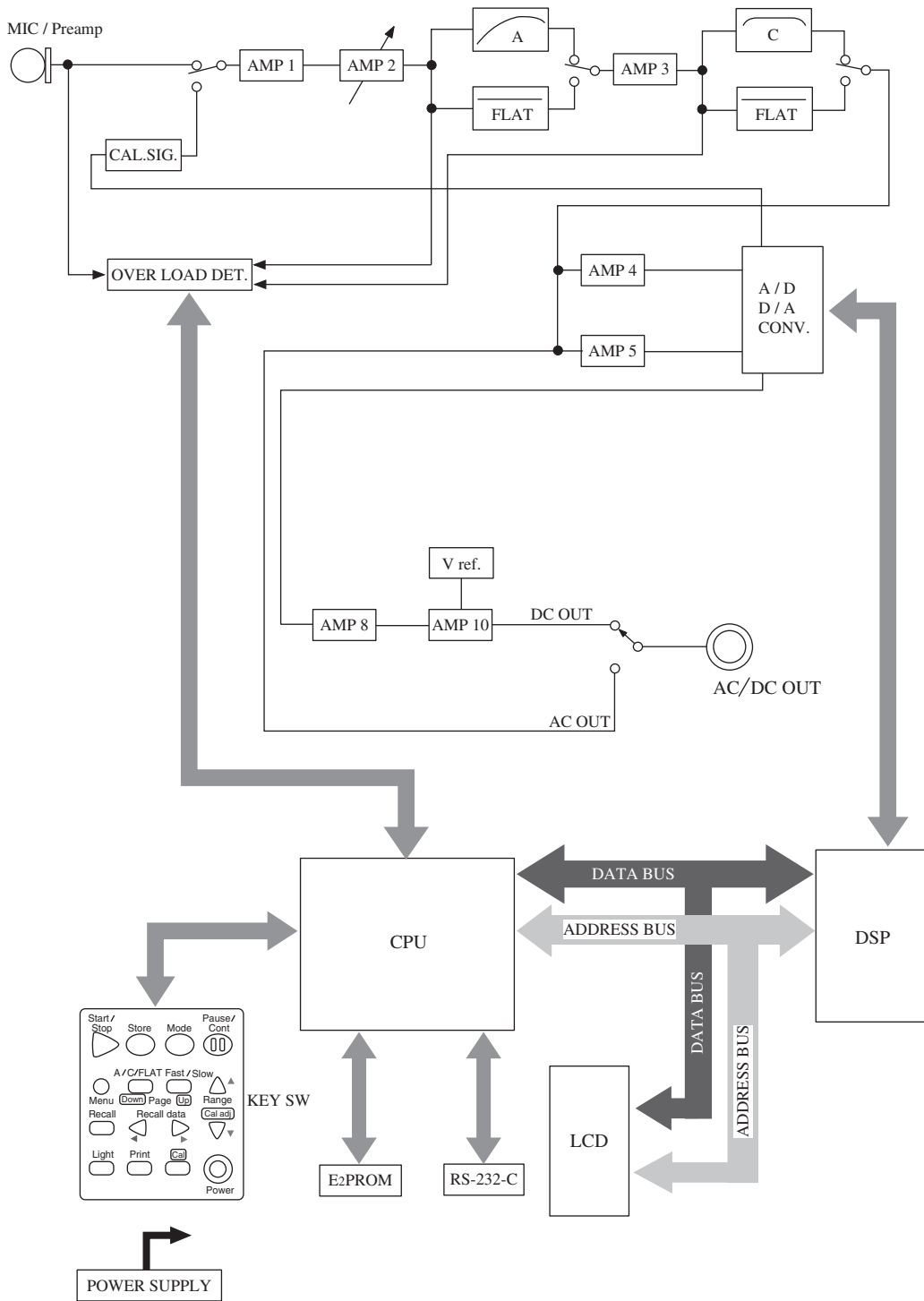

NL-20 Block Diagram

Controls and Functions

Front View

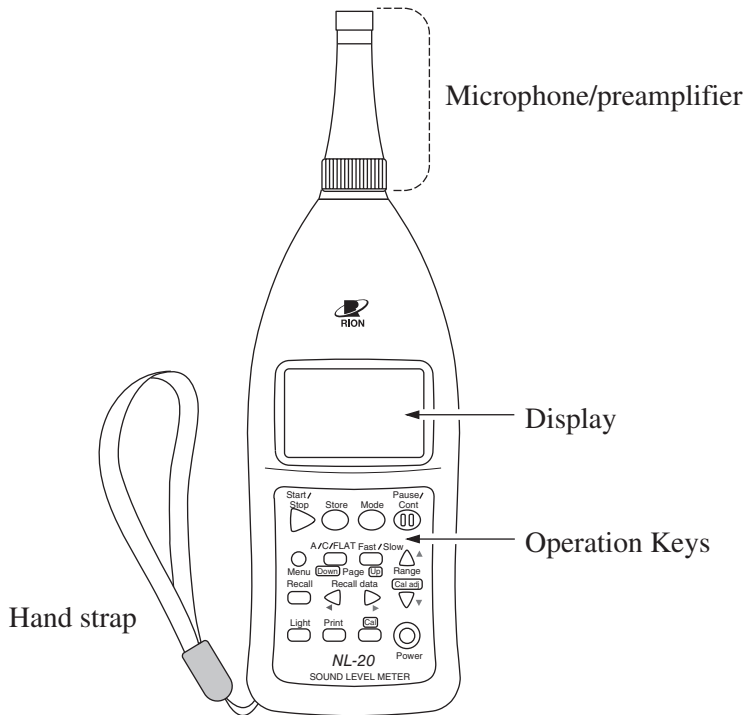

Microphone/preamplifier

The microphone and preamplifier are configured as an integrated assembly. The assembly can be removed from the sound level meter and connected via an optional extension cable, for measurements a distance.

Display

This backlit LCD shows the sound level as a numeric reading and a bar graph. The display also shows the operation mode of the sound level meter, the selected measurement parameters, warning indications etc.

Hand strap

Makes the unit easy to carry and hold on your palm.

Operation Keys

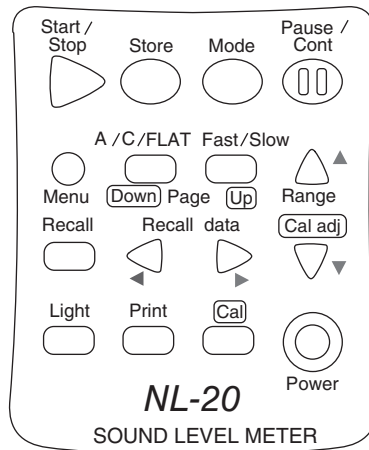

Start/Stop key

Press to start or stop the sound level measurement (including the various processing functions).

Store key

Press to store measurement data in memory.



Mode key

This key is used for reading the measurement results. With each push of the button, the display format is switched according to the processing types selected from the menu.

Pause/Cont key

During a measurement, this key can be used to exclude unwanted portions from processing. Pressing the key again causes processing to be resumed. It is also possible to use the key for excluding an interval of up to 5 seconds before the key was pressed.

Menu key

When this key is pressed, the menu screen 1/3 appears on the display. Pressing the key again switches the display back to the original condition. Menu pages are switched with the Page   keys to the right of the key.

A/C/FLAT key

Sets frequency weighting to A, C or FLAT.

Fast/Slow key

Sets the time weighting to Fast or Slow.

Range ▲ , ▼ keys

Select the level range for the measurement.

The following six settings are available:

20 to 80, 20 to 90, 20 to 100, 20 to 110, 30 to 120, 40 to 130

Recall key

Serves to recall data stored in the memory of the unit.

Recall Data ◀ , ▶ keys

When the display shows the measurement screen, these keys select the data number in which to store data next.

When the display shows data from memory, the keys select the data number to be displayed.

Light key

This key activates the backlight for easier viewing of the display in low-light conditions. To turn the backlight off, press the key once more. When the automatic light out function was selected from the menu, the light will turn itself off automatically after 5 minutes.

Print key

When the optional printer DPU-414, CP-11, or CP-10 is connected, pressing this key initiates a printout.

Cal key

Pressing this key activates the built-in oscillator for electrical calibration of the NL-20 or for level matching of the unit and connected equipment.

Power key

Turns the unit on and off when you hold the key down for more than 1 second.

Hand strap

Attach the Hand strap to the unit as shown below. The strap makes it easier to carry the unit and serves as a precaution against dropping it. Pass the strap over your wrist, as shown in the illustration.

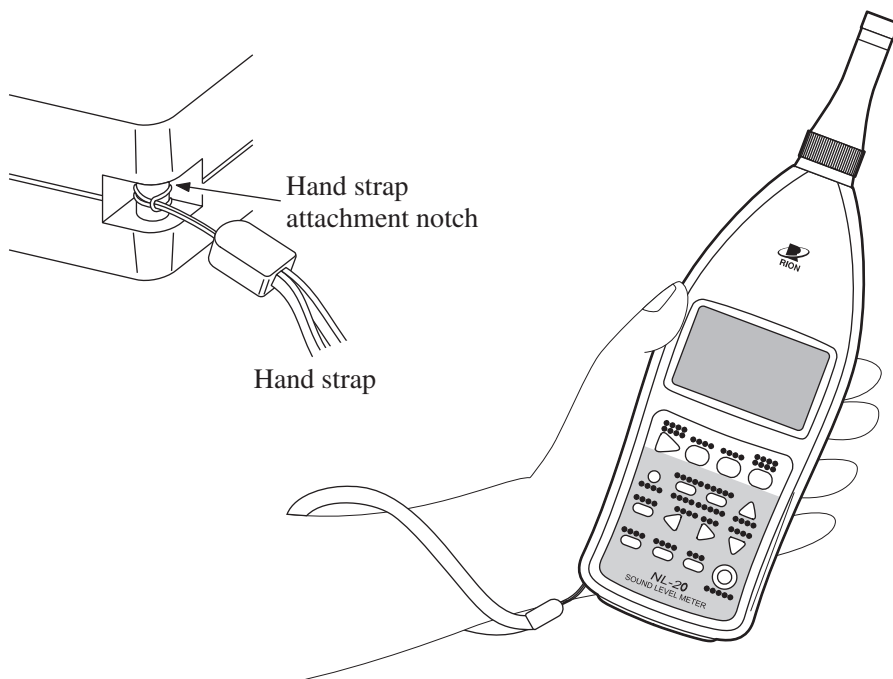

Using the hand strap

Bottom View

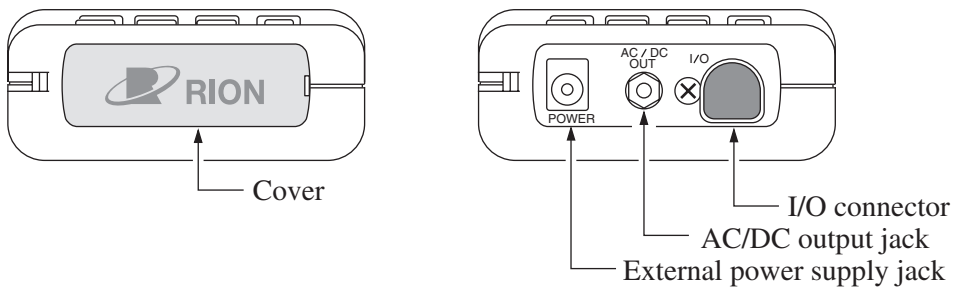

Cover

This cover protects the connectors on the bottom during transport or storage. Removing the cover gives access to the connectors shown above.

External power supply jack

The optional AC adapter NC-98A, NC-98B or NC-34 series can be connected here for powering the unit from an AC outlet.

| Important |
|---|
| To prevent the risk of damage, do not use any AC adapter other than the specified type. |

AC/DC output jack

The signal selected on menu screen 3/3 is output here.

AC: AC signal (with frequency weighting)

DC: DC signal corresponding to sound level

I/O connector

This input/output connector serves for input of control signals and input/output of measurement data. A printer, level recorder, or computer can be connected here.

Rear View

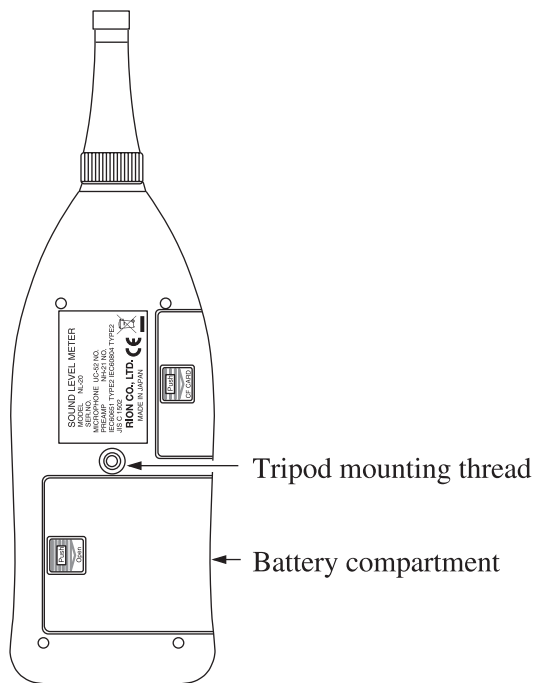

Tripod mounting thread

The unit can be mounted on a camera tripod using this thread.

Battery compartment

Four batteries (IEC R6P, size AA) are inserted here.

Preparations

Power Supply

The unit can be powered by four IEC R6P (size AA) batteries (alkaline or manganese) or by the specified optional AC adapter (NC-98A, NC-98B or NC-34 series).

It is possible to use size AA rechargeable batteries, but a separate recharger must be provided for such batteries, since the unit is not designed to recharge batteries.

Before inserting or replacing the batteries and before connecting the AC adapter, be sure to turn power to the unit off.

| Note |
|---|
| When the AC adapter is connected, the unit will be powered from the adapter, also when batteries are inserted. (The AC adapter has priority.) In case of a power failure or other interruption of AC power, the unit will automatically switch to battery power and continue to operate. |

Inserting the batteries

1. Lightly press the cover of the battery compartment and slide it to the right.
2. Insert the four IEC R6P batteries, paying attention to the polarity as indicated in the compartment.
3. Replace the cover.

Lightly press here and slide to the right

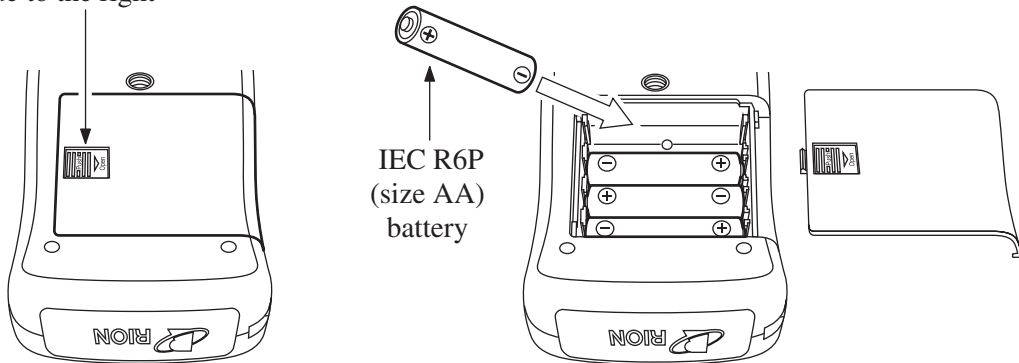

The life of a set of batteries depends on usage conditions and various other factors. Some reference values are shown below.

| | | | Continuous use |
|-------|---------------------|-----|------------------|
| NL-20 | Alkaline batteries | LR6 | Approx. 34 hours |
| | Manganese batteries | R6P | Approx. 14 hours |

When display backlighting is used, battery life will be about half of the above values.

When auxiliary processing is ON, battery life will be about 20 percent shorter.

Important

Take care not to reverse the (+) and (-) polarity when inserting the batteries.

Always replace all four batteries together.

Do not mix old and new batteries or batteries of different type.

Remove the batteries from the unit, if the unit is not to be used for a month or longer.

AC adapter (option)

Connect the AC adapter as shown below.

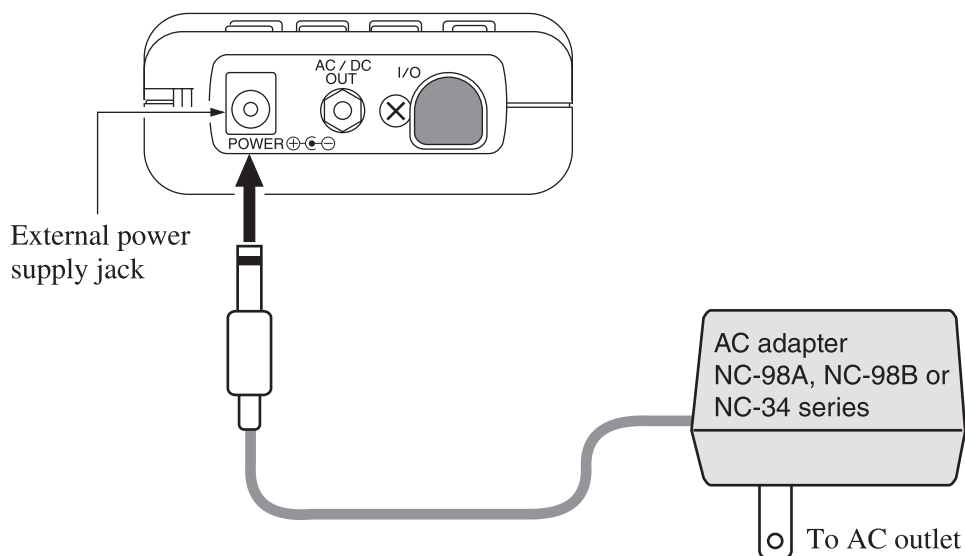

Important

To prevent the risk of damage, do not use any AC adapter other than the NC-98A, NC-98B or NC-34 series (both available as options).

Windscreen (WS-10)

When making outdoor measurements in windy weather or when measuring air conditioning equipment or similar, wind noise at the microphone can cause measurement errors. Such effects can be reduced by using the windscreen WS-10. For information on the influence of the windscreen on wind noise etc., please refer to the separate Technical Notes.

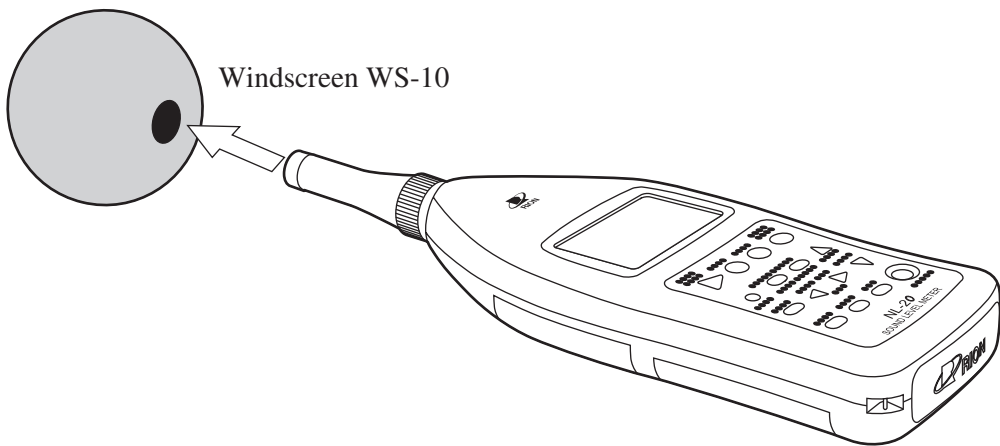

Tripod Mounting

For long-term measurements, the unit can be mounted on a camera tripod. Proceed carefully, to avoid dropping the unit or tipping over the tripod.

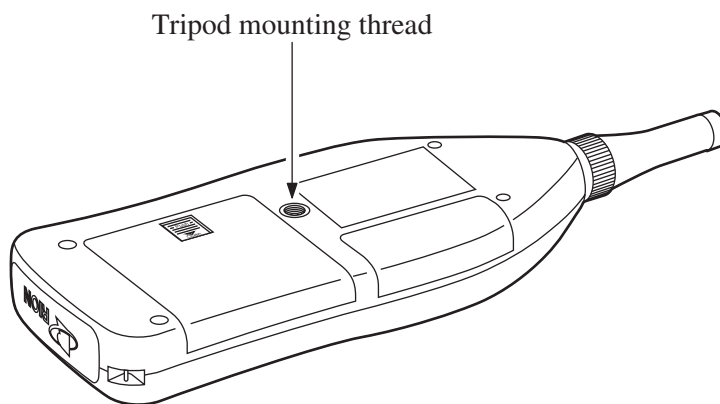

Microphone Extension Cables (EC-04 series)

Turn power to the unit off before separating the microphone from the main unit. To reduce measurement deviations due to refraction effects and the acoustic influence of the operator, the microphone can be detached from the unit and connected via an extension cable. Optional cables are listed in the table below.

Extension cable EC-04 series

| Model | Length | Model | Length |
|--------|--------|--------|---------------------------------------|
| EC-04 | 2 m | EC-04C | 30 m (reel) + 5 m (connection cable) |
| EC-04A | 5 m | EC-04D | 50 m (reel) + 5 m (connection cable) |
| EC-04B | 10 m | EC-04E | 100 m (reel) + 5 m (connection cable) |

It is also possible to connect several cables in series.

Important

With long extension cables, the cable capacitance restricts the upper measurement frequency and measurement level. For details, please refer to the Technical Notes.

1. Loosen the preamplifier fastening screw and remove the preamplifier from the main unit.

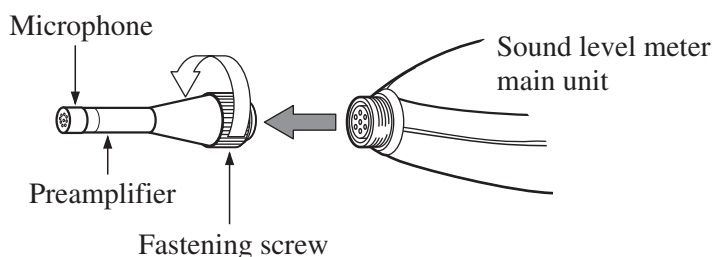

Important

Never separate the microphone and preamplifier, because this can lead to damage.

2. Connect the extension cable to the preamplifier and to the main unit and fasten the connectors with the fastening screw.
3. When mounting the microphone on a tripod, first fasten the microphone holder (supplied with the extension cable) to the tripod. Then insert the extension cable connector into the microphone holder.

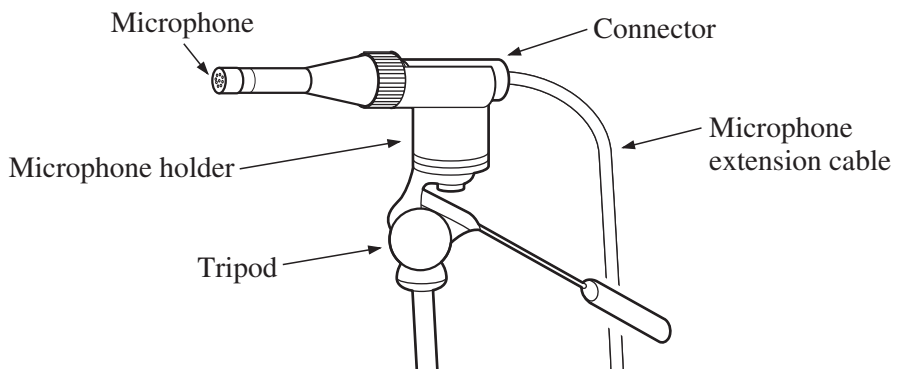

Connection to a Printer (DPU-414, CP-11, CP-10)

The I/O port on the bottom of the unit can be used for connection of an optional printer (DPU-414, CP-11, CP-10). Use the optional printer cable CC-93 to connect the I/O port of the unit to the serial input of the printer.

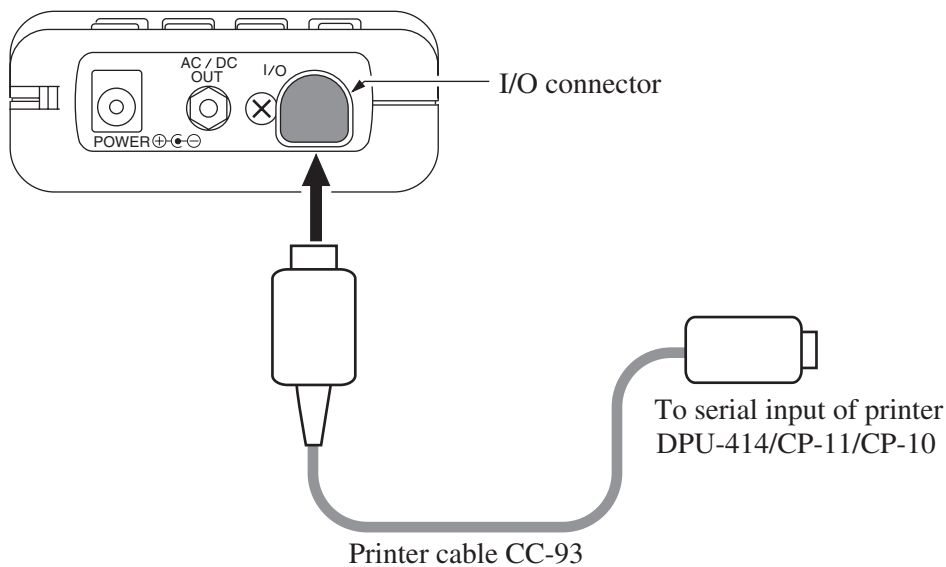

Setting the software DIP switches of the DPU-414

Turn on the power while holding down the ON LINE key of the DPU-414. A printout showing the current status of the printer is produced.

An example showing suitable software DIP switch settings for use of the printer with the NL-20 is shown below. (The actual printout will be in a different font.)

```
Continue ? : Push' On-line SW'
Write ?   : Push' Paper feed SW'
Dip SW-1
  1 (OFF) : Input = Serial
  2 (ON)  : Printing Speed = High
  3 (ON)  : Auto Loading = ON
  4 (OFF) : Auto LF = OFF
  5 (ON)  : Setting Command = Enable
  6 (OFF) : Printing
  7 (ON)  : Density
  8 (ON)  : 100 %
```

```
Continue ? : Push' On-line SW'
Write ?   : Push' Paper feed SW'
Dip SW-2
  1 (OFF) : Printing Columns = 80
  2 (ON)  : User Font Back-up = ON
  3 (ON)  : Character Select = Normal
  4 (ON)  : Zero = Normal
  5 (ON)  : International
  6 (ON)  : Character
  7 (ON)  : Set
  8 (ON)  : =Japan
```

```
Continue ? : Push' On-line SW'
Write ?   : Push' Paper feed SW'
Dip SW-3
  1 (ON)  : Data Length = 8 bits
  2 (ON)  : Parity Setting = ON
  3 (OFF) : Parity Condition = Even
  4 (OFF) : Busy Control = XON / XOFF
  5 (OFF) : Baud
  6 (ON)  : Rate
  7 (ON)  : Select
  8 (OFF) : = 19200 bps
```

```
Continue ? : Push'-line SW'
Write ?   : Push' Paper feed SW'
```

DIP SW setting complete !!

For details, please refer to the documentation of the DPU-414. Set the baud rate of the sound level meter to 19200 bps.

Setting the software DIP switches of the CP-11/CP-10

Set the DIP switches of the printer as follows.

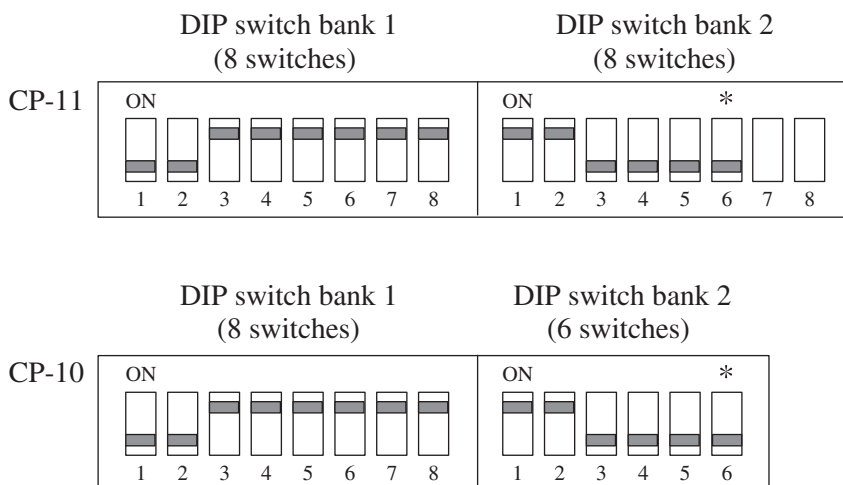

Important

The switch marked with an asterisk (switch 6 of DIP switch bank 2) serves for setting the transfer speed. The ON position means 4800 bps and the OFF position 9600 bps. This setting must match the setting of the unit.

Switches 7 and 8 of DIP switch bank 2 of printer CP-11 are set at the factory and should not be changed. Otherwise, correct printing may not be possible.

Connection to a Level Recorder (LR-06, LR-07, LR-04, LR-20A)

Sound level recording

Connect the AC/DC output on the bottom of the unit to the level recorder, as shown below.

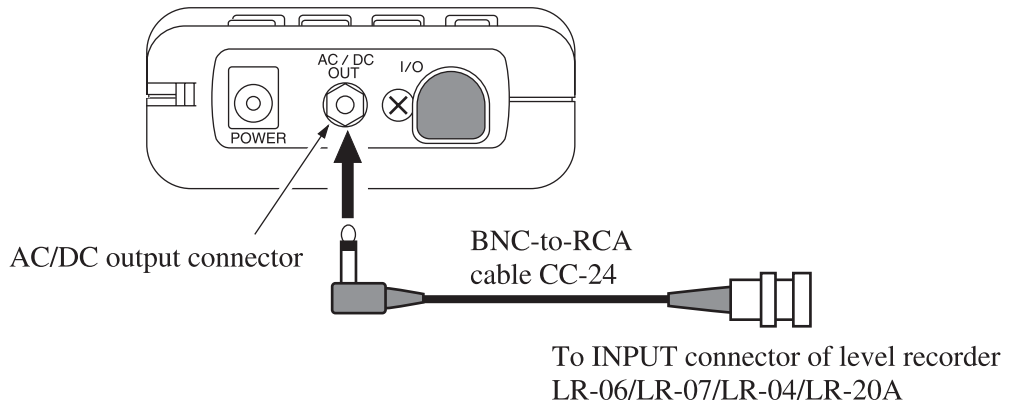

Connection to a Computer

Connect the I/O port on the bottom of the unit to the RS-232-C interface of the computer, using the optional interface cable.

For details, please refer to the Serial Interface Manual.

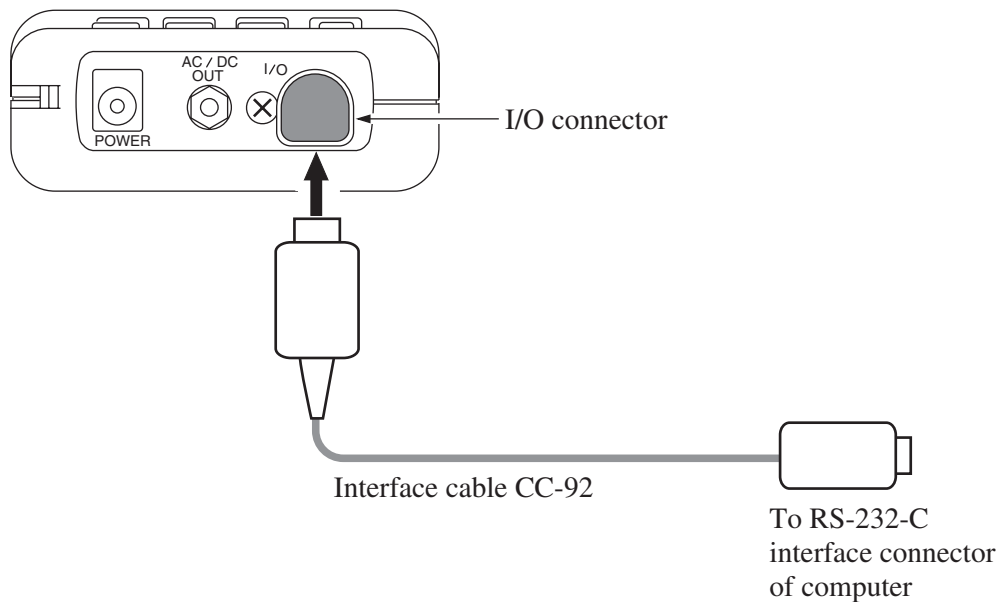

Measurement in Dark Locations

Pressing the Light key turns the display backlight on, making it easier to read in dark locations. Pressing the key once more turns the light off.

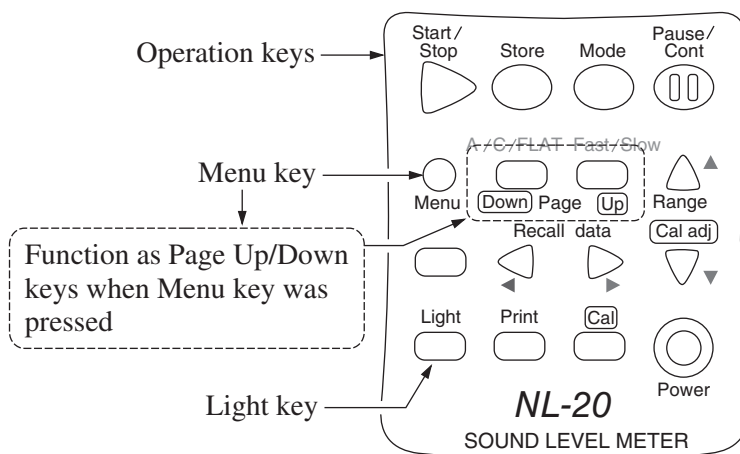

If the “Light Auto Off” item on the menu screen 3/3 is set to “5 min”, the backlight turns itself off automatically after 5 minutes. When the item is set to “Cont.”, backlighting is turned on and off with the Light key.

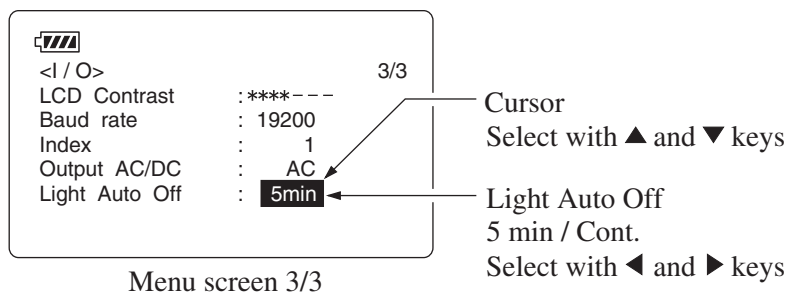

When the backlight is used continuously, battery life will be shortened to about half.

LCD Contrast

You can adjust the contrast of the display.

1. Press the Menu key.
The display changes to the menu screen.
2. Use the Page Up/Down keys to switch to menu screen 3/3.
3. Use the ▲ and ▼ keys to move the cursor to the LCD Contrast * marks.
(The display is shown in reverse.)
4. Increase or decrease number of * marks with ◀ and ▶ keys to adjust contrast

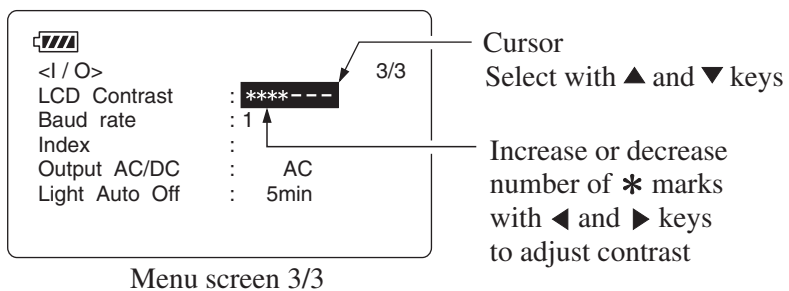
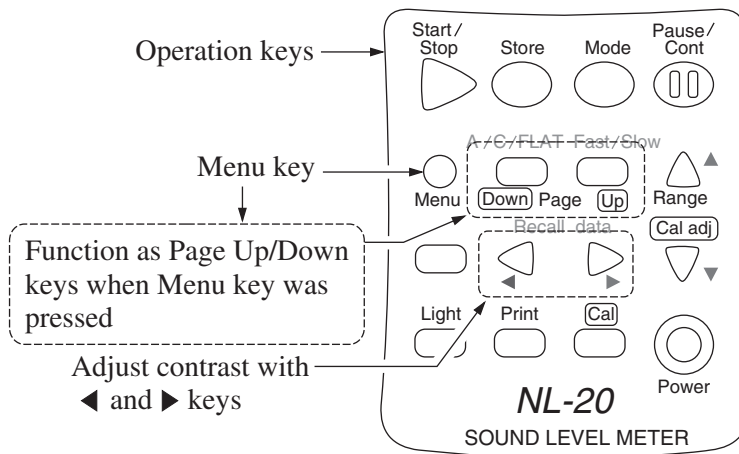

5. Press the Menu key again to return to the measurement screen.

Calibration

Before starting a measurement, the unit must be calibrated. There are two types of calibration: electrical calibration and acoustic calibration using a pistonphone. Normally, electrical calibration only is required.

Electrical calibration

The built-in oscillator (1 kHz, sinusoidal wave) is used for electrical calibration.

1. Turn the unit on by pressing the Power key.
2. Use the Level Range ▲ and ▼ keys to select the 30 to 120 dB range.
3. Press the Menu key to bring up the menu display.
4. Use the Page Up/Down keys to show menu screen 1/3.

Verify that the Cal Mode is set to “Internal”.

If “External” is shown, use the ▲ and ▼ keys to move the cursor to “External” and use the ◀ and ▶ keys to set it to “Internal”.

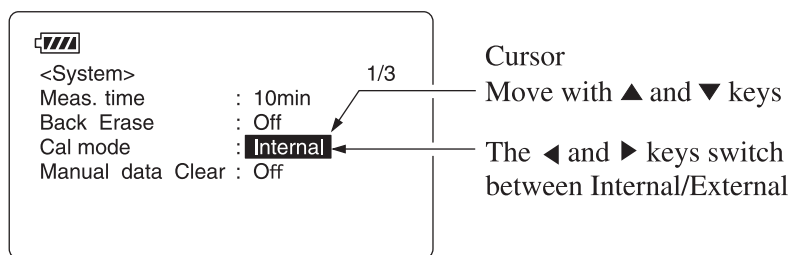
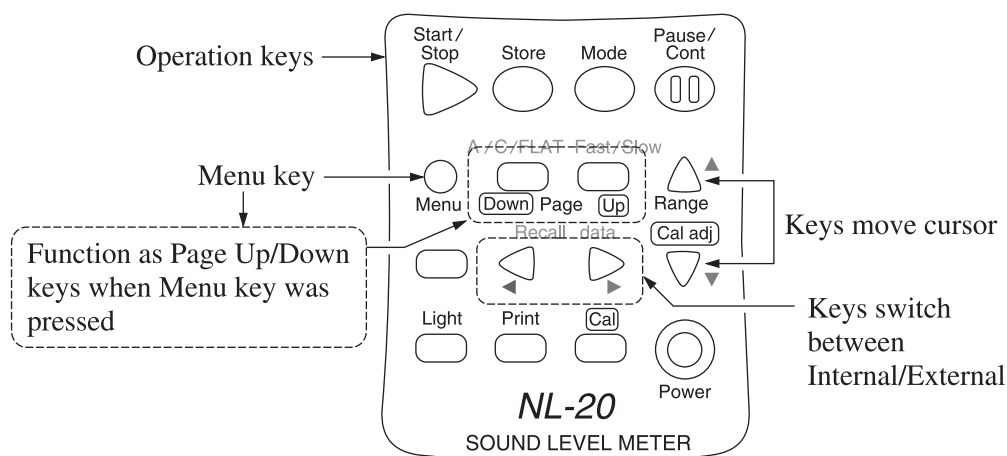

Menu screen 1/3

- Press the Menu key again to return to the measurement screen.
Press the Cal key. The display becomes as shown below.

If the level range is not set to 30 to 120 dB, the indication of 114 dB flashes, and the required calibration value is 6 dB under the range maximum. For example, if the level range is set to 130 dB, the indication of 124 dB flashes.

- Use the ▲ and ▼ keys to set the level display to 114.0 dB.

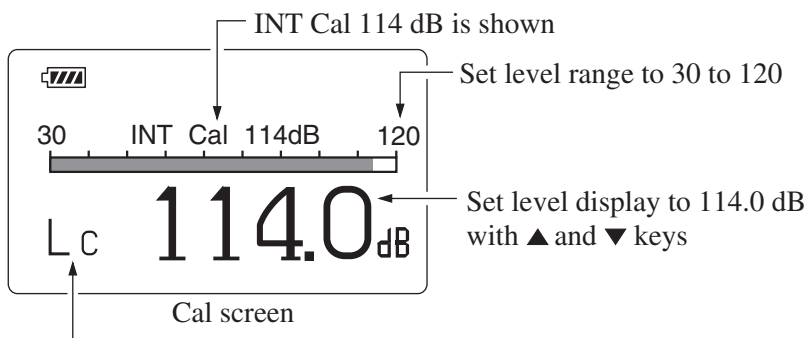

Frequency weighting automatically becomes L_C

Frequency weighting is temporarily set to "C". When the Cal key is pressed again, the original settings are restored.

Signal output for calibration of external equipment

The normal level range for calibration is 30 to 120 dB, but in order to allow calibration of external equipment, calibration can also be performed at other level range settings (Press the Level Range keys). In this case, the “XX dB” indication of the calibration value flashes.

Perform the setting so that the calibration value is 6 dB under the maximum of the selected range.

In this case, the AC output or DC output is used to calibrate connected equipment.

1. Use the ▲ and ▼ keys to set the level indication to the calibration value (maximum -6 dB).
2. Press the Cal key again to return to normal measurement mode.

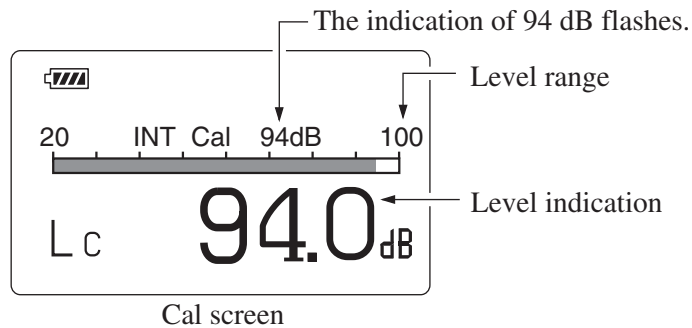

Note

Calibration cannot be performed if the unit is in a measurement mode other than sound level measurement (including triangle mark flashing in top left of screen, and pause). Perform calibration after measurement is completed (Start/Stop key was pressed).

Acoustic calibration with sound calibrator NC-74 or pistonphone NC-72A

For acoustic calibration, the Rion sound calibrator NC-74 or pistonphone NC-72A is mounted to the microphone of the sound level meter, and adjustment is performed so that the reading of the meter is equal to the sound level inside the coupler.

| Important |
|--|
| Be very careful when inserting and removing the microphone to and from the coupler, to avoid a sudden pressure buildup which could destroy the membrane of the microphone. |

1. Turn off the sound calibrator or the pistonphone.
2. Turn on the NL-20.
3. Press the Menu key to bring up the menu display.
4. Use the Page Up/Down keys to show menu screen 1/3.
Verify that the Cal Mode is set to “External”.
If “Internal” is shown, use the ▲ and ▼ keys to move the cursor to “Internal” and use the ◀ and ▶ keys to set it to “External”.

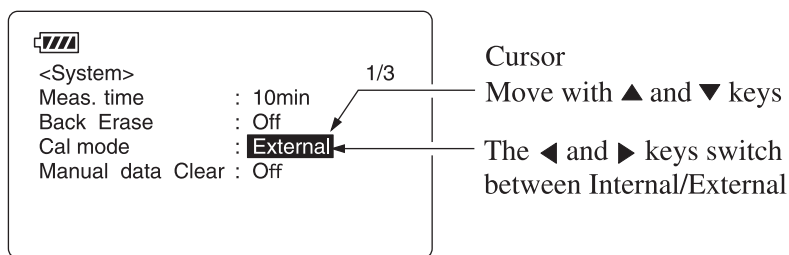
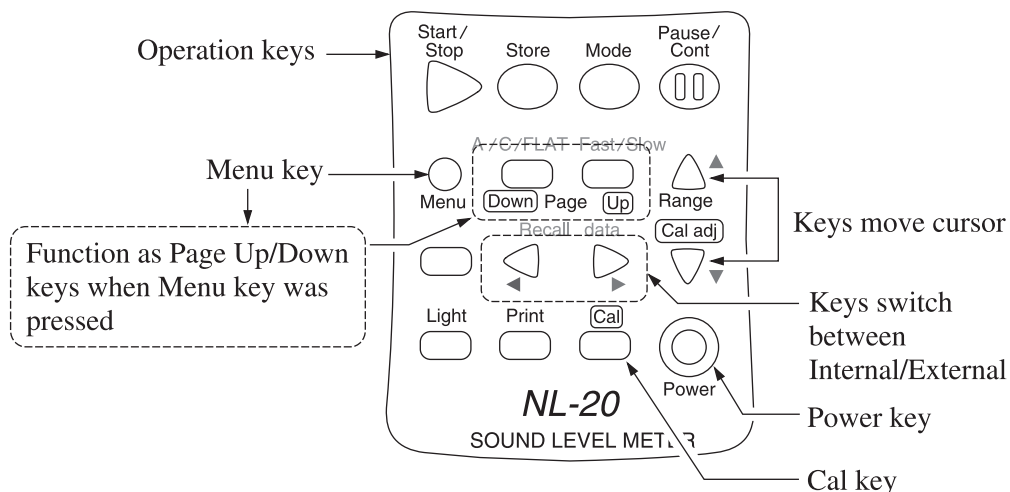

Menu screen 1/3

5. Press the Menu key again to return to the measurement screen.
6. Use the Level Range ▲ and ▼ keys to select the 30 to 120 dB range. If the level range is not set to 30 to 120 dB, the EXT Cal indication flashes.

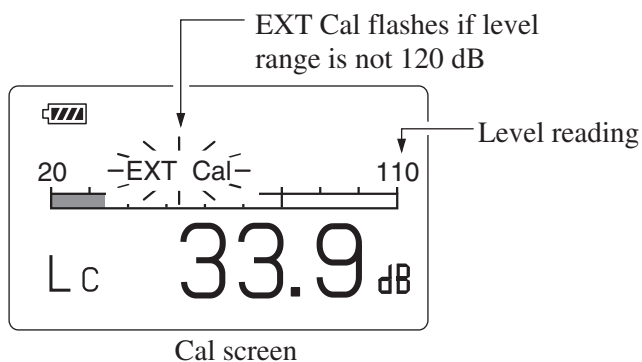

7. Press the Cal key.
8. Mount the 1/2-inch adapter on the coupler of the NC-74 or NC-72A.

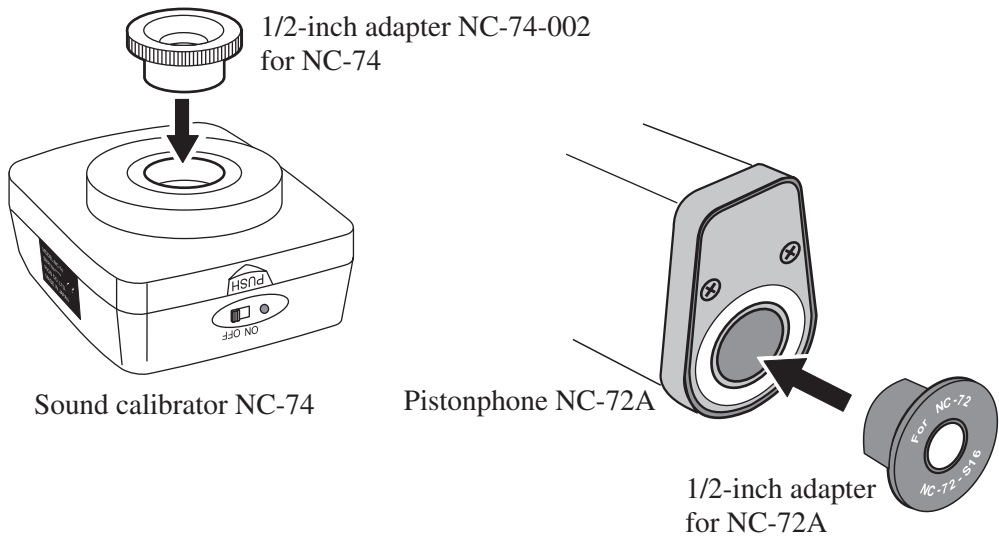

9. Insert the microphone very carefully and slowly all the way into the coupler.
10. Set the power switch of the sound calibrator or the pistonphone to ON.
11. Use the ▲ and ▼ keys to adjust the reading to 93.9 dB if the NC-74 is used, or to the value indicated on the pistonphone if the NC-72A is used.

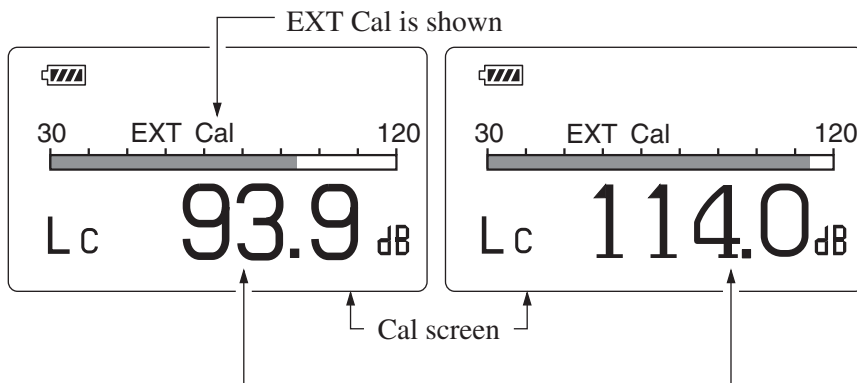

Level indication when NC-74 is used
(displayed sound pressure level of NL-20)

Level indication when NC-72A is used
(correct figure is indicated on NC-72A)

12. Turn off the sound calibrator or the pistonphone and NL-20.
13. Remove the microphone very carefully and slowly from the coupler.

| Note |
|---|
| For details on operation of the NC-74 or NC-72A, please refer to the instruction manual for them. For information about compensation for atmospheric pressure, please refer to the documentation of the pistonphone NC-72A. |
| The NC-74 is designed to produce 94.0 dB under its rated conditions, but in actual calibration, the sound field compensation value which depends on the sound level meter must be taken into consideration. For the NL-20, adjust the reading to 93.9 dB. |

Reading the Display

Display screen

The illustration below is for demonstration purposes only. In actual use, not all display elements will be visible at the same time, and the size and font of the display may differ.

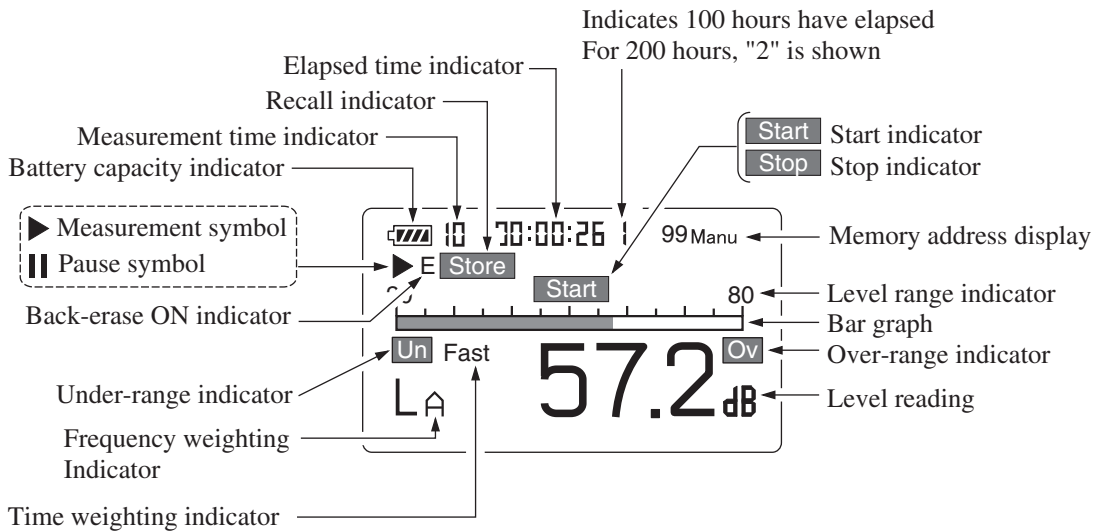

▶ Measurement symbol

Flashes while a measurement is in progress and while data are being stored in memory.

▬▬ Pause symbol

Lights up when processing or storing is paused. In the paused condition, the sound level reading is not updated but bar graph is updated.

Battery capacity indicator

When operating the unit on batteries, periodically check this indicator to determine the remaining battery capacity. The number of black segments decreases as the batteries are used up. When the display starts to flash, correct measurement is no longer possible. Replace the batteries with a fresh set.

The indicator is also displayed while the unit is powered from the AC adapter.



Measurement time indicator

Shows the selected measurement time. If no measurement time was selected (arbitrary measurement time), the indication is blank.

The following measurement time settings are possible:

10 s (seconds), 1 m (minute), 5 m, 10 m, 15 m, 30 m, 1 h (hour), 8 h, 24 h, None

Recall indicator

Lights up when data stored in memory are being displayed.

Elapsed time indicator

During processing and memory store, this indicator shows the elapsed time in seconds. If the time has exceeded 100 hours, the top digit of the address indicator shows “1”.

Start indicator

This indicator appears for 1 second at measurement start.

Stop indicator

This indicator appears for 1 second at measurement stop.

Memory address display

Shows the memory address of stored data.

Level range indicator

Shows the upper and lower limit of the bar graph. Make the setting that is appropriate for the sound level.

Bar graph

Shows the sound level. The indication is updated every 100 milliseconds.

Over-range indicator (shown as for sound level)

Shown when sound level overload has occurred.

Over-range indicator (shown as for processed value)

Shown when any of the processed values contains an over-range level.
Lights up when over-range occurs during processing and stays lit until the next processing measurement starts.

Level reading

Normally, this shows the sound level (updated every second).

Time weighting indicator

Shows the selected time weighting setting.

Frequency weighting indicator

Shows the selected frequency weighting setting.

L_A : A weighting

L_C : C weighting

L_p : FLAT

The third and fourth digit are shown when processed values are displayed.

The meaning is as follows.

L_{Aeq} , L_{Ceq} , L_{peq} : Equivalent continuous sound level

L_{AE} , L_{CE} , L_{pE} : Sound exposure level

L_{Amax} , L_{Cmax} , L_{pmax} : Maximum sound level

L_{Amin} , L_{Cmin} , L_{pmin} : Minimum sound level

L_{A05} , L_{C05} , L_{p05} : 5% percentile sound level

L_{A10} , L_{C10} , L_{p10} : 10% percentile sound level

L_{A50} , L_{C50} , L_{p50} : 50% percentile sound level

L_{A90} , L_{C90} , L_{p90} : 90% percentile sound level

L_{A95} , L_{C95} , L_{p95} : 95% percentile sound level

Under-range indicator (shown as **Un** for sound level)

Shown when the sound level has fallen below -2.6 dB of the level range lower limit, or below the measurement range. Shown for at least one second.

Under-range indicator (shown as **Un** for processed value)

Shown when any of the processed values contains an under-range level. Lights up when an under-range condition occurs during processing and stays lit until the next processing measurement starts.

Back-erase ON indicator

Lights up when the data back-erase function (page 62) is enabled.

Menu screens

There are three menu screens numbered 1/3 through 3/3.

Menu screen 1/3

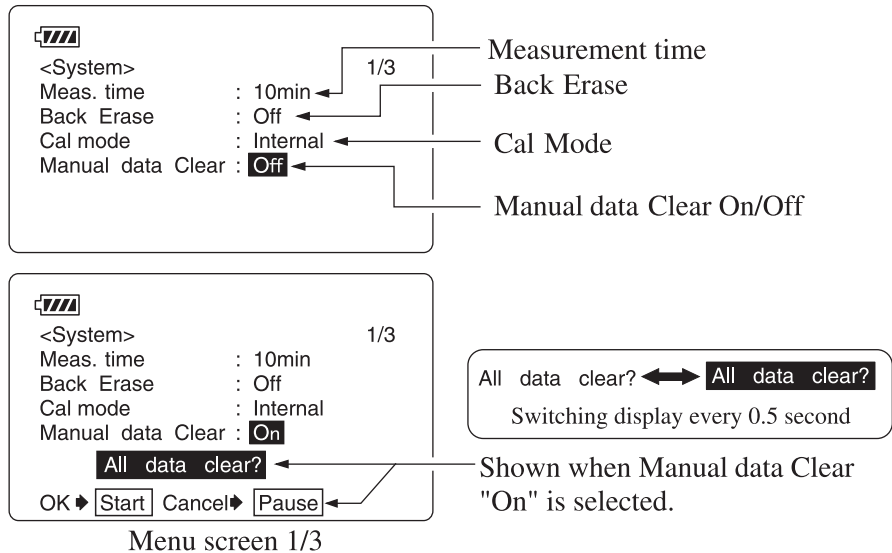

Meas. time (measurement time)

Use ◀, ▶ keys to select the measurement time.

Manual → 10 sec → 1 min → 5 min → 10 min → 15 min → 30 min → 1 hour → 8 hours → 24 hours → Manual → ...

Back Erase (data exclusion function)

This function allows excluding the last 5 seconds before activation of the pause condition from processing.

Off: Normal pause function

5 sec: 5 seconds preceding pause are excluded

Cal mode (calibration mode)

Internal: Select this position for electrical calibration of the unit using the built-in oscillator.

External: Select this position for acoustic calibration of the unit using a pistonphone.

Manual Data Clear

Determines whether stored data are to be cleared or not. When “On” is selected, the indication “ OK ▶ **Start** Cancel ▶ **Pause** “ is shown on the next line. To clear the data, press the [Start] key. To cancel the process and return to the previous menu screen (1/3), press the Pause key.

Menu screen 2/3

| | | | |
|---|-------|-----|-------|
|  | | | |
| <Display> | | 2/3 | |
| Leq | : On | LN | : Off |
| LE | : Off | LN | : Off |
| Lmax | : Off | LN | : On |
| Lmin | : Off | LN | : Off |
| LIST | : On | LN | : Off |
| | | T-L | : On |

Menu screen 2/3

Leq: Equivalent continuous sound pressure level
 LE: sound exposure level
 Lmax: Maximum value
 Lmin: Minimum value
 LIST: List display
 LN: Percentile sound pressure level
 T-L: Time/Level

Leq (Equivalent continuous sound level)

Set to “On” if the processing result is to be displayed, otherwise set to “Off”.

LE (Sound exposure level)

Set to “On” if the processing result is to be displayed, otherwise set to “Off”.

Lmax (Maximum value), Lmin (Minimum value)

Set to “On” if the processing result is to be displayed, otherwise set to “Off”.

LIST (List display)

Set to “On” if the processing result is to be displayed, otherwise set to “Off”.

LN (Percentile sound level)

Can be set from L01 to L99.

Set to “On” if the processing result is to be displayed, otherwise set to “Off”.

T-L (Time/Level)

Set to “On” if the processing result is to be displayed, otherwise set to “Off”.

Menu screen 3/3

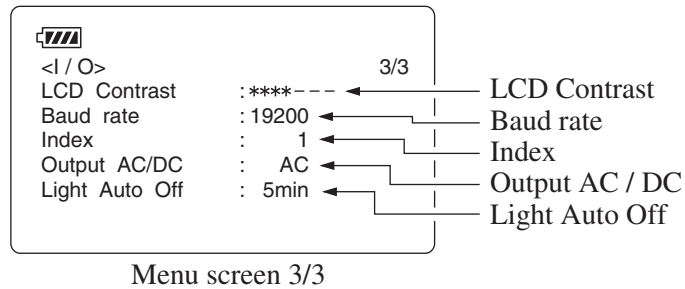

LCD Contrast

The number of * symbols corresponds to the contrast setting. It can be changed with the ◀ and ▶ keys.

Baud rate (I/O transfer speed)

You can select 4800 bps, 9600 bps or 19200 bps with the ◀ and ▶ keys.

Index

This is a number identifying the unit when multiple units (up to 255) are used.

Output AC/DC

Selects whether an AC or DC signal is output from the I/O connector.

Light Auto Off

Controls the automatic backlight turn-off function. When set to “Cont.,” backlight on/off is controlled only by the Light key and is not automatically turned off.

Measurement screen examples

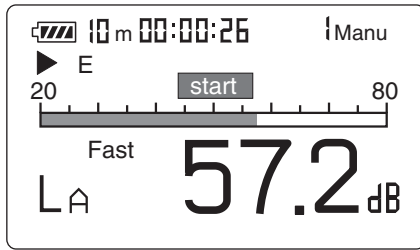

Sound pressure level example

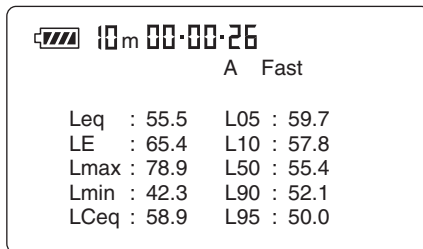

List display example

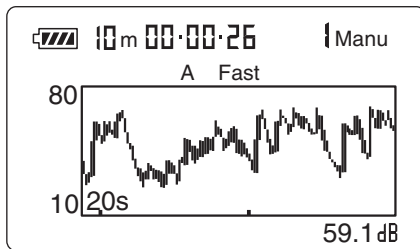

T-L (time level) display example

Power On/Off

Power-on

Turn the unit on by holding down the Power key for at least one second. When the power-on screen appears, release the Power key. After the initial screen was shown, the unit switches to the measurement screen.

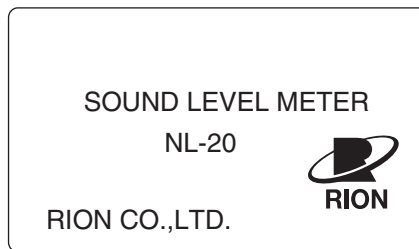
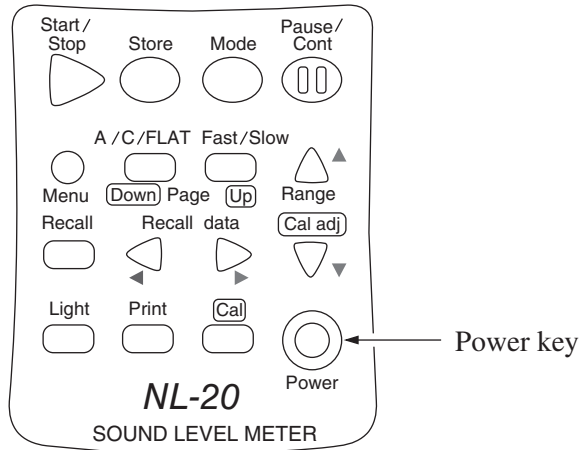

Power-on screen

Power-off

Turn the unit off by holding down the Power key for at least one second. When the power-off screen appears, release the Power key.

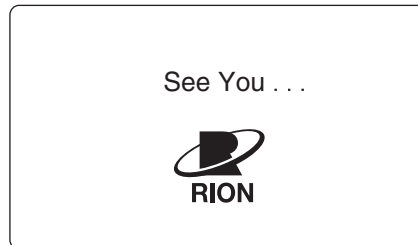

Power-off screen

| Note |
|---|
| Wait at least 5 seconds after turning the unit off before you turn it on again. |

Measurement

When using this unit in a mode other than sound level measurement, all processing functions provided by the unit are carried out simultaneously. For example, when equivalent continuous sound level measurement is selected, the sound exposure level and percentile level are also determined. However, the time percentage setting for the percentile level (5 values) must be selected beforehand.

Sound level Measurement

The procedure for sound level measurement is described below.

Preparations as described in the previous chapter must be completed first.

Sound level

1. Turn the unit on by pressing the Power key.

After the power-on screen, the measurement screen is shown.

The various settings depend on the condition the unit was in before it was last turned off.

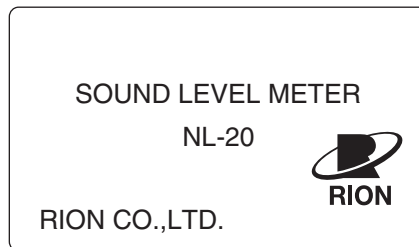

Power-on screen

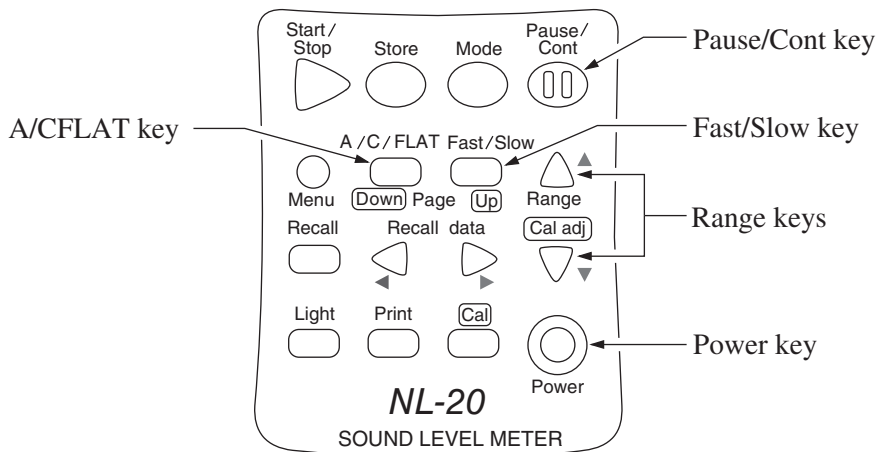

2. Select the frequency weighting with the A/C/FLAT key. For normal sound level measurements, select the “A” setting.
If “ L_p ” (FLAT) is selected, the sound level from 20 Hz to 8 kHz can be measured.
3. Use the Fast/Slow key to select the time weighting (dynamic characteristics). Normally, the “Fast” setting should be used.
4. When performing measurements according to IEC or other standards, the frequency weighting and time weighting setting required by the standard should be selected.
5. Use the Level Range keys to select the level range. Choose a setting in which the bar graph indication registers to about the middle of the range. If the “**Ov**” (Over) or “**Un**” (Under) indicators light up frequently, change the level range setting.

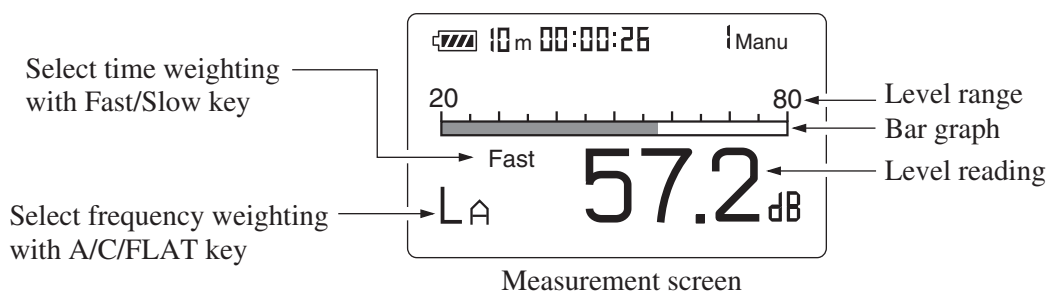

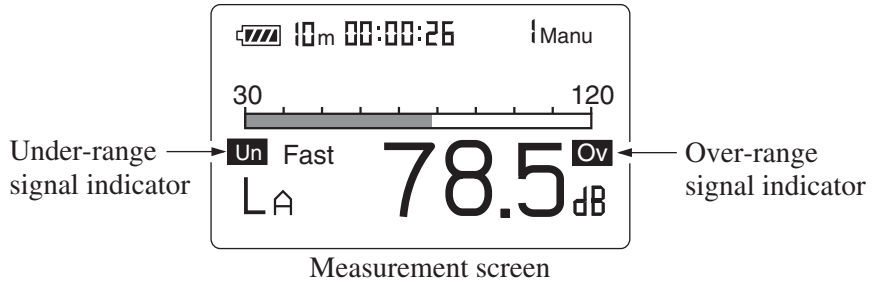

- The numeric level indication shows the currently measured sound level. The reading is updated once every second. The Pause/Cont key can be used to stop and start the level reading from being updated. The bar graph indication is updated during pause condition. In the pause condition, a **||** mark appears on the display. Pressing the Pause/Cont key once more resumes the measurement.

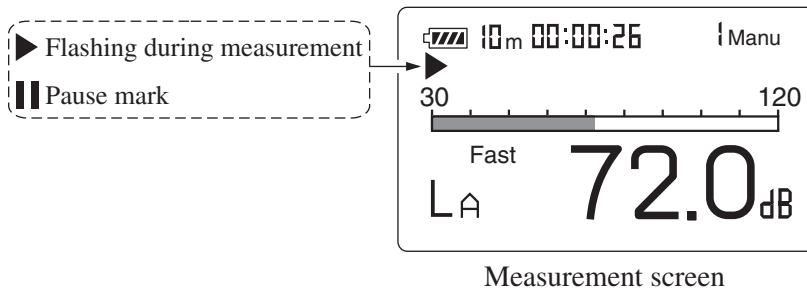

| Important | |
|--|------------------------------------|
| During sound level measurement, do not press the Mode key because this causes the processing results to be displayed. As shown in the example, if the letter following “L” is displayed without an appendix, sound level measurement is being carried out. | |
| L _A | Display shows sound level. |
| L _{Aeq} | Display does not show sound level. |

Equivalent Continuous Sound level (L_{Aeq}) Measurement

The procedure for equivalent continuous sound level measurement is described below.

Preparations as described in the previous chapter must be completed first.

1. Turn the unit on by pressing the Power key.
2. Select the frequency weighting with the A/C/FLAT key. For normal measurements, select the “A” setting.
When “C” (C weighting) is selected, the equivalent continuous sound level (L_{Ceq}) is measured.
3. Use the Fast/Slow key to select the time weighting. Normally, the “Fast” setting should be used.

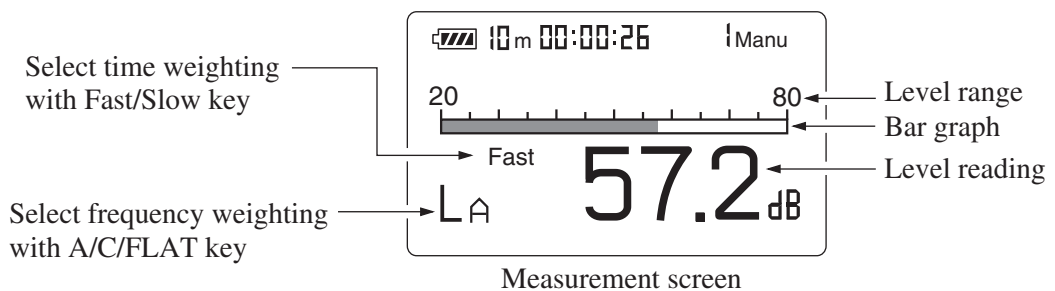

4. Use the Level Range keys to select the level range. Choose a setting in which the bar graph indication registers to about the middle of the range. If the “Ov” (Over) or “Un” (Under) indicators light up frequently, change the level range setting.

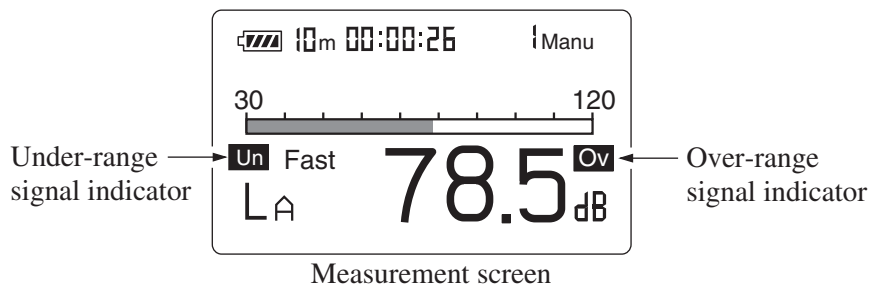

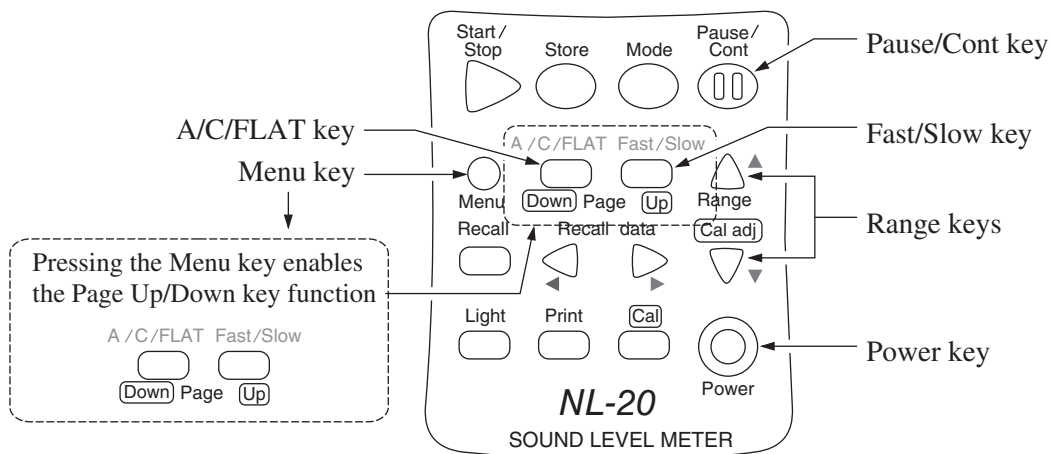

Note

This unit uses high-speed sampling of the sound pressure waveform for L_{eq} and L_E processing (30.3 μ s). The result is therefore unaffected by dynamic characteristics and accurate also for a short time period.

5. Use the menu to set the measurement time.
Press the Menu key to call up the menu screen 1/3.
6. Use the ▲ and ▼ keys to move the cursor to the “Meas. time” item, and use the ◀ and ▶ keys to select the measurement time.

Manual → 10 sec → 1 min → 5 min → 10 min → 15 min → 30 min
 → 1 hour → 8 hours → 24 hours → Manual → ...

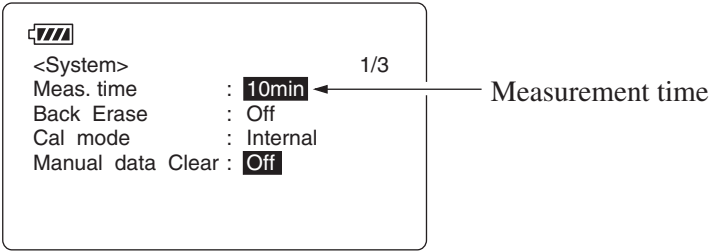

Menu screen 1/3

7. Use the Page Up/Down keys to display the menu screen 2/3.
If L_{eq} : Off is displayed, use the ▲ and ▼ keys to move the highlight to “Off”, and use the ◀ and ▶ keys to set the item to “On”.

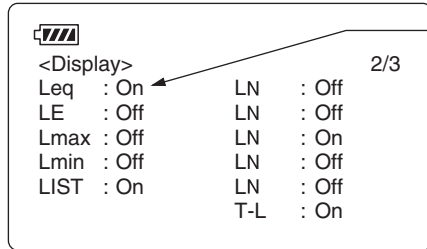

L_{eq} : Set equivalent continuous sound level display to "On".

Menu screen 2/3

8. To use the data exclusion (back-erase) function, please refer to page 62.

Note

In addition to the regular pause function it is also possible to exclude (back-erase) data from the immediately preceding 5 seconds.

9. Press the Menu key to return to the measurement screen.
10. Press the Start/Stop key to start the measurement.
During measurement, the ▶ symbol flashes and the elapsed measurement time is displayed.

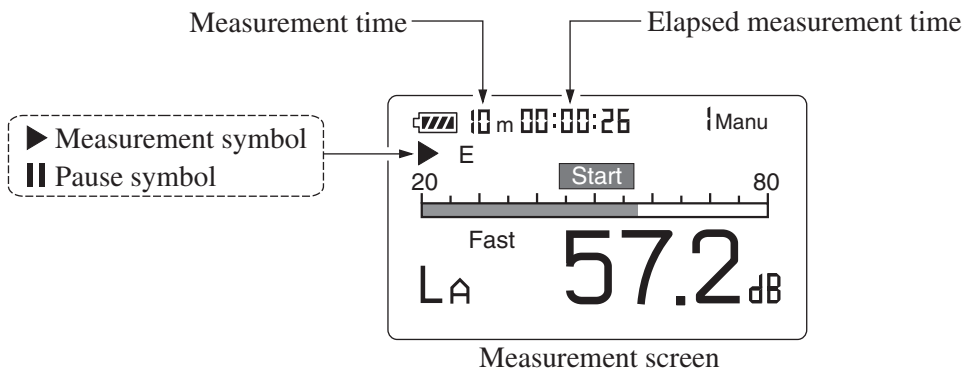

When the measurement time set in step 6 has elapsed, the measurement terminates automatically. When wishing to terminate the measurement earlier, press the Start/Stop key.

If Manual was selected, the Start/Stop key must be used to conclude the measurement.

If an under-range condition or over-range condition occurs at least once during measurement, the “Ov” (Over) or “Un” (Under) indicator appears, to show that the processing data contain over-range or under-range data.

Important

During measurement, most of the keys such as the A/C/FLAT key and Level keys are in-operative. Only the following four keys can be used: Start/Stop, Pause/Cont, Mode, Light. All other settings must be made before starting the measurement.

During measurement, the Pause/Cont key can be used to pause and resume the measurement. During pause, the pause symbol (||) is shown. (Any pause intervals and the back-erase time if data back-erase is enabled are not included in the measurement time.)

If data back-erase was enabled in step 8, the data are indicated on the display, as shown below.

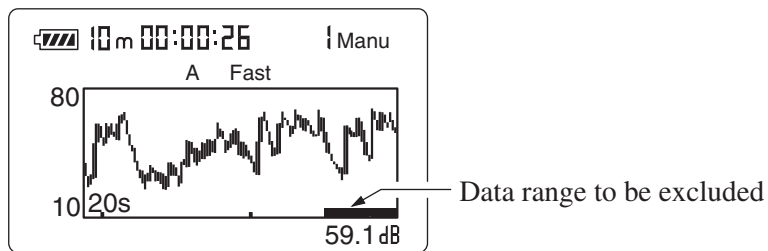

Measurement screen

11. When the measurement is completed, you can use the Mode key to switch between various ways of displaying the measurement result. When L_{Aeq} is shown, the equivalent continuous sound level is being displayed.

If L_{Aeq} is not shown, check whether L_{Aeq} on the menu screen 2/3 is set to “On”.

If “**OV**” (Over) is shown, the sound level data used for processing contained over-range data.

If “**Un**” (Under) is shown, the sound level data used for processing contained under-range data.

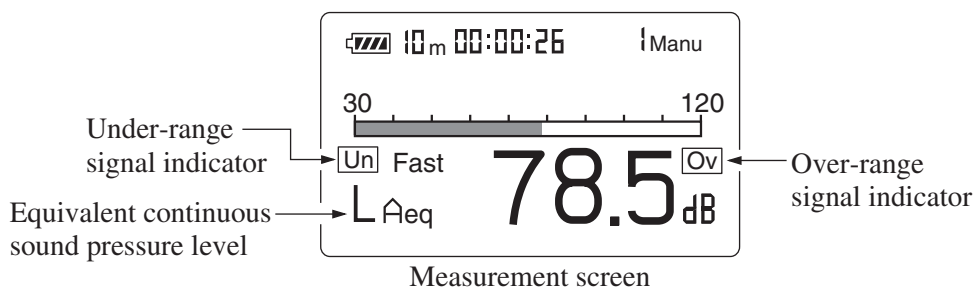

Note

It is also possible to use the Mode key during measurement to read the equivalent continuous sound level up to that point. (This applies only to the numeric level display. The bar graph indication shows the sound level.)

Changing the A/C/FLAT or Fast/Slow setting after measurement is completed has no effect on the displayed processing result.

Sound Exposure Level (L_{AE}) Measurement

The procedure for sound exposure level measurement is described below. Preparations as described in the previous chapter must be completed first.

1. Turn the unit on by pressing the Power key.
2. Select the frequency weighting with the A/C/FLAT key. For normal measurements, select the “A” setting.
3. Use the Fast/Slow key to select the time weighting (dynamic characteristics). Normally, the “Fast” setting should be used.

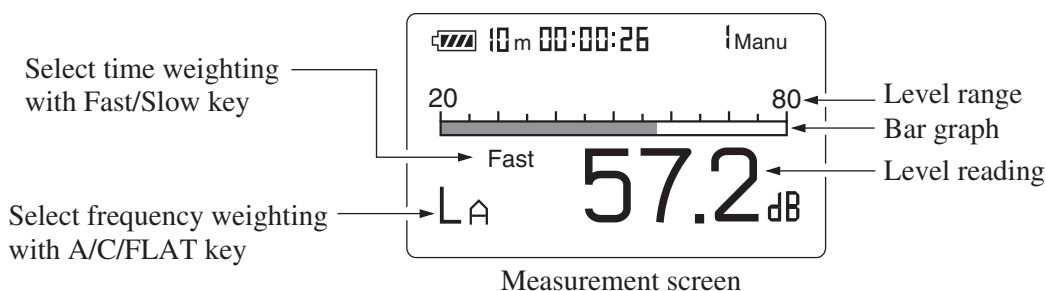

4. Use the Level Range keys to select the level range. Choose a setting in which the bar graph indication registers to about the middle of the range. If the “Ov” (Over) or “Un” (Under) indicators light up frequently, change the level range setting.

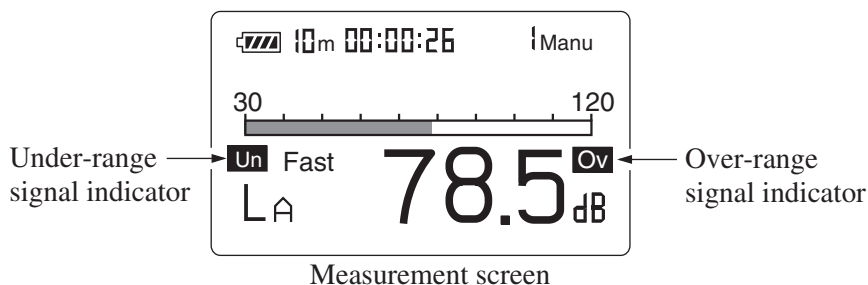

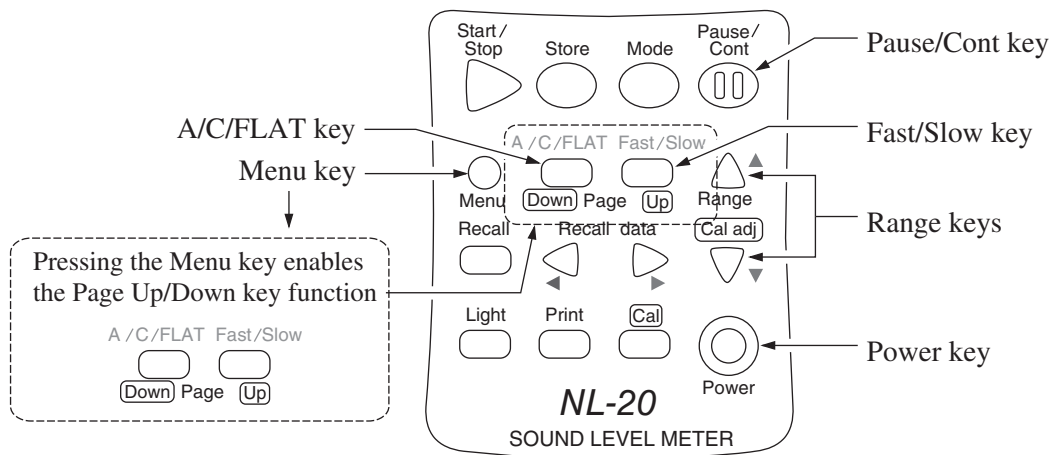

Note

This unit uses high-speed sampling of the sound pressure waveform for L_{eq} and L_E processing (30.3 μ s). The result is therefore unaffected by dynamic characteristics and accurate also for a short time period.

5. Use the menu to set the measurement time.
Press the Menu key to call up the menu screen 1/3.
6. Use the ▲ and ▼ keys to move the cursor to the “Meas. time” item, and use the ◀ and ▶ keys to select the measurement time.

Manual → 10 sec → 1 min → 5 min → 10 min → 15 min → 30 min → 1 hour → 8 hours → 24 hours → Manual → ...

When Manual is selected, the measurement time is controlled by the operator. The maximum time is 200 hours.

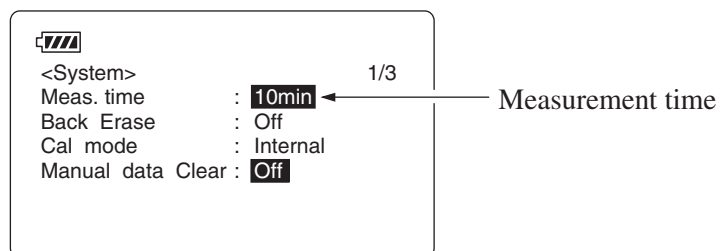

Menu screen 1/3

7. Use the Page Up/Down keys to display the menu screen 2/3.
 If L_E : Off is displayed, use the ▲ and ▼ keys to move the highlight to “Off”, and use the ◀ and ▶ keys to set the item to “On”.

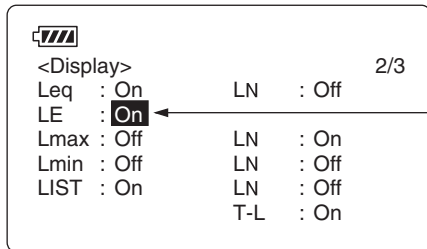

L_E : Set sound exposure level display to "On".

Menu screen 2/3

8. To use the data exclusion (back-erase) function, please refer to page 62.

Note

In addition to the regular pause function it is also possible to exclude (back-erase) data from the immediately preceding 5 seconds.

9. Press the Menu key to return to the measurement screen.
10. Press the Start/Stop key to start the measurement.
 During measurement, the ▶ symbol flashes and the elapsed measurement time is displayed.

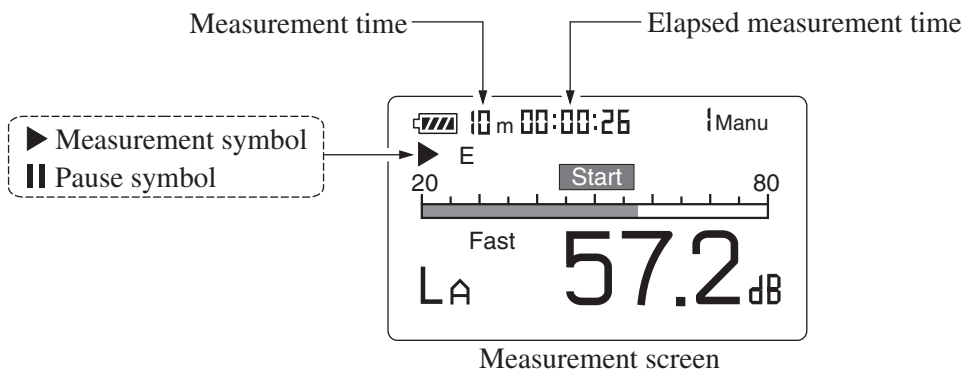

When the measurement time set in step 6 has elapsed, the measurement terminates automatically. When wishing to terminate the measurement earlier, press the Start/Stop key.

If no display (arbitrary measurement time) was selected, the Start/Stop key must be used to conclude the measurement.

Important

During measurement, most of the keys such as the A/C/FLAT key and Level keys are in-operative. Only the following four keys can be used: Start/Stop, Pause/Cont, Mode, Light. All other settings must be made before starting the measurement.

During measurement, the Pause/Cont key can be used to pause and resume the measurement. During pause, the pause symbol (||) is shown. (Any pause intervals and the back-erase time if data back-erase is enabled are not included in the measurement time.)

If data back-erase was enabled in step 8, the data are indicated on the display, as shown below.

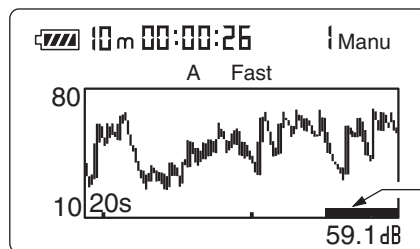

Measurement screen

11. When the measurement is completed, you can use the Mode key to switch between various ways of displaying the measurement result. When L_{AE} is shown, the sound exposure level is being displayed. If L_{AE} is not shown, check whether L_{AE} on the menu screen 2/3 is set to “On”.
- If “**OV**” (Over) is shown, the sound level data used for processing contained over-range data.
- If “**Un**” (Under) is shown, the sound level data used for processing contained under-range data.

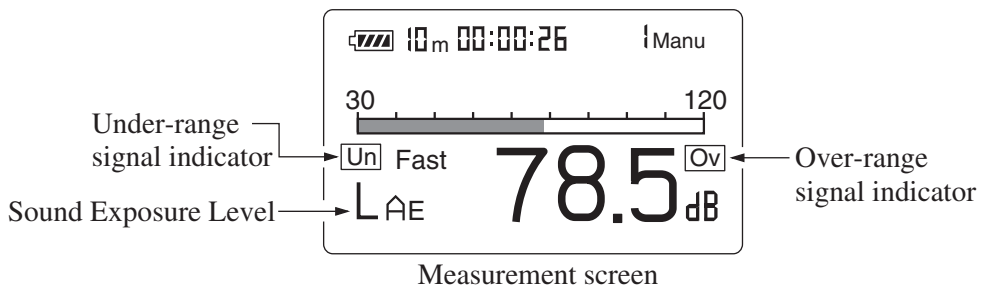

| Note |
|--|
| It is also possible to use the Mode key during measurement to read the equivalent continuous sound level up to that point. (This applies only to the numeric level display. The bar graph indication shows the sound level.) |
| Changing the A/C/FLAT or Fast/Slow setting after measurement is completed has no effect on the displayed processing result. |

Maximum (L_{\max}) and Minimum (L_{\min}) Sound level Measurement

The procedure for maximum and minimum sound level measurement is described below.

Preparations as described in the previous chapter must be completed first.

1. Turn the unit on by pressing the Power key.
2. Select the frequency weighting with the A/C/FLAT key. For normal measurements, select the “A” setting.
3. Use the Fast/Slow key to select the time weighting. Normally, the “Fast” setting should be used.

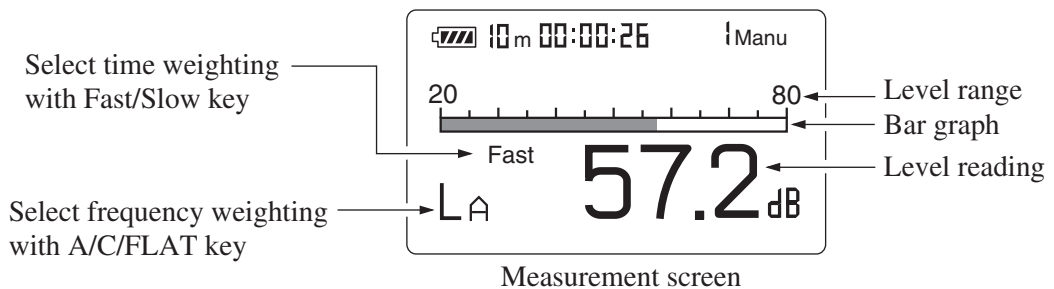

4. Use the Level Range keys to select the level range. Choose a setting in which the bar graph indication registers to about the middle of the range. If the “**Ov**” (Over) or “**Un**” (Under) indicators light up frequently, change the level range setting.

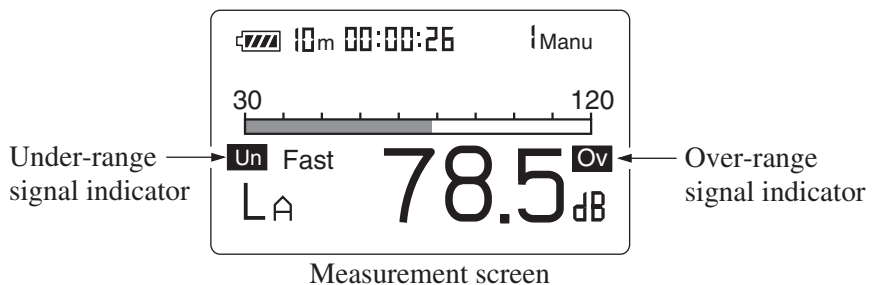

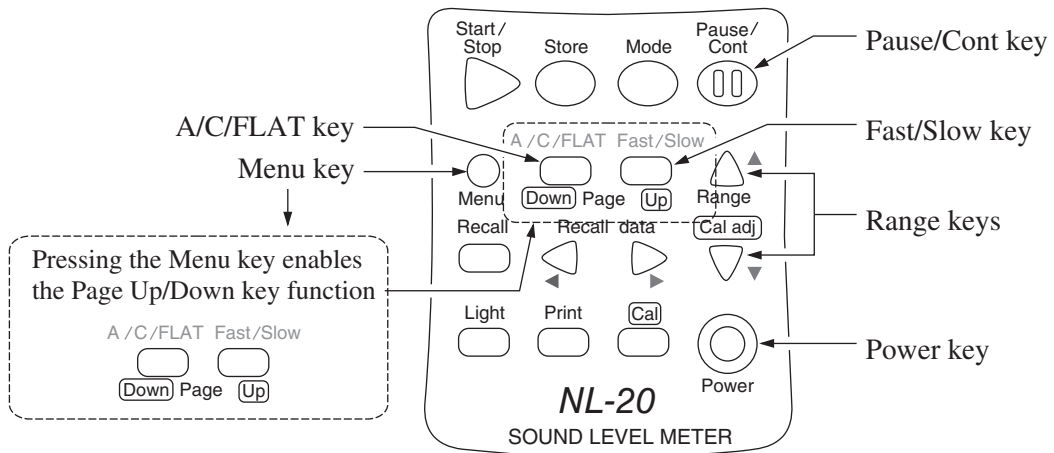

5. Use the menu to set the measurement time.
Press the Menu key to call up the menu screen 1/3.
6. Use the ▲ and ▼ keys to move the cursor to the “Meas. time” item, and use the ◀ and ▶ keys to select the measurement time.

Manual → 10 sec → 1 min → 5 min → 10 min → 15 min → 30 min
→ 1 hour → 8 hours → 24 hours → Manual → ...

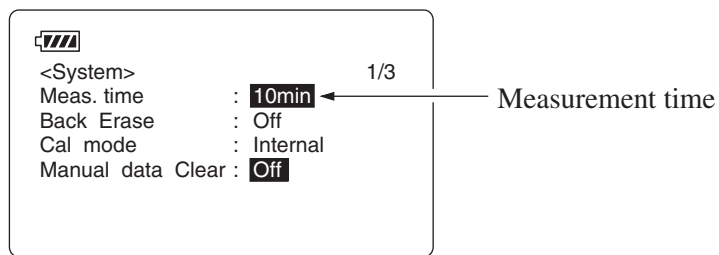

Menu screen 1/3

7. Use the Page Up/Down keys to display the menu screen 2/3.
If L_{\max} : Off, L_{\min} : Off is displayed, use the ▲ and ▼ keys to move the highlight to “Off”, and use the ◀ and ▶ keys to set the item to “On”.

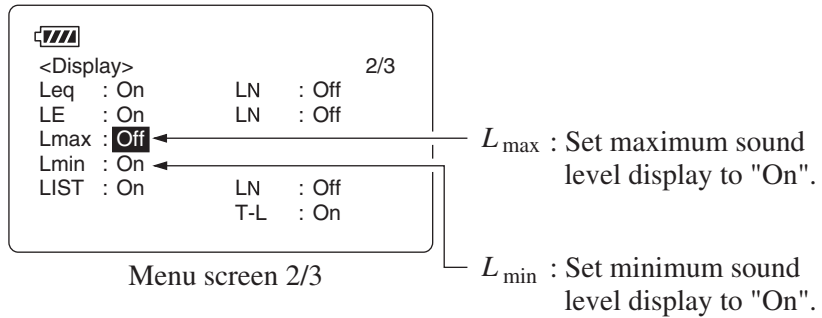

8. Press the Menu key to return to the measurement screen.
9. Press the Start/Stop key to start the measurement.
During measurement, the ▶ symbol flashes and the elapsed measurement time is displayed.

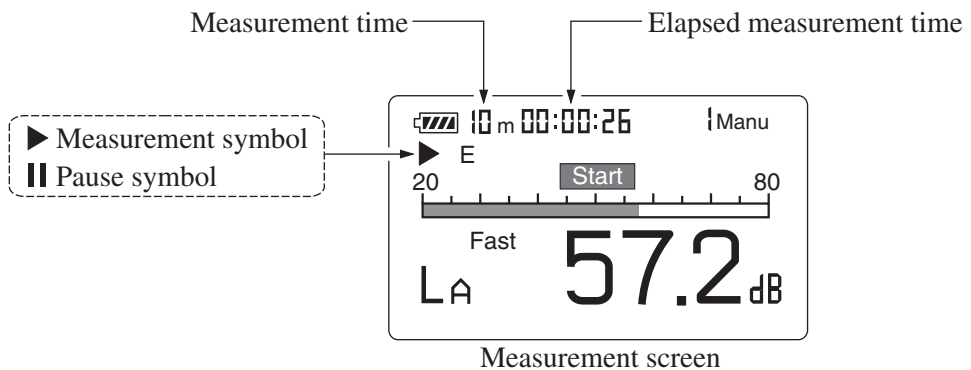

When the measurement time set in step 6 has elapsed, the measurement terminates automatically. When wishing to terminate the measurement earlier, press the Start/Stop key.

If no display (arbitrary measurement time) was selected, the Start/Stop key must be used to conclude the measurement.

Important

During measurement, most of the keys such as the A/C/FLAT key and Level keys are in-operative. Only the following four keys can be used: Start/Stop, Pause/Cont, Mode, Light. All other settings must be made before starting the measurement.

During measurement, the Pause/Cont key can be used to pause and resume the measurement. During pause, the pause symbol (⏸) is shown. (Any pause intervals and the back-erase time if data back-erase is enabled are not included in the measurement time.)

10. When the measurement is completed, you can use the Mode key to switch between various ways of displaying the measurement result. When L_{Amax} is shown, the maximum sound level is being displayed. When L_{Amin} is shown, the minimum sound level is being displayed. If L_{Amax} and L_{Amin} are not shown, check whether L_{max} and L_{min} on the menu screen 2/3 are set to “On”.

If an over-range or under-range condition has occurred at least once during the measurement, the “[Ov]” (Over) or “[Un]” (Under) indication is shown on the display, to indicate that over-range or under-range data were included in the sound level measurement values used for processing.

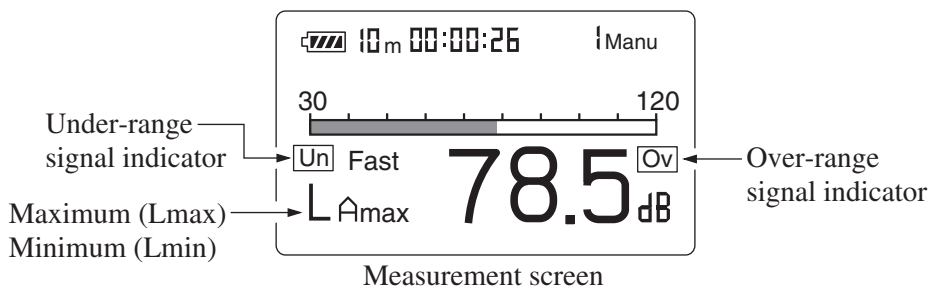

Note

It is also possible to use the Mode key during measurement to read the maximum or minimum sound level up to that point. (This applies only to the numeric level display. The bar graph indication shows the sound level.)

Note

Changing the A/C/FLAT or Fast/Slow setting after measurement is completed has no effect on the displayed processing result.

Percentile Sound level (L_N) Measurement

The procedure for percentile sound level measurement is described below. Preparations as described in the previous chapter must be completed first.

1. Turn the unit on by pressing the Power key.
2. Select the frequency weighting with the A/C/FLAT key. For normal measurements, select the “A” setting.
3. Use the Fast/Slow key to select the time weighting (dynamic characteristics). Normally, the “Fast” setting should be used.

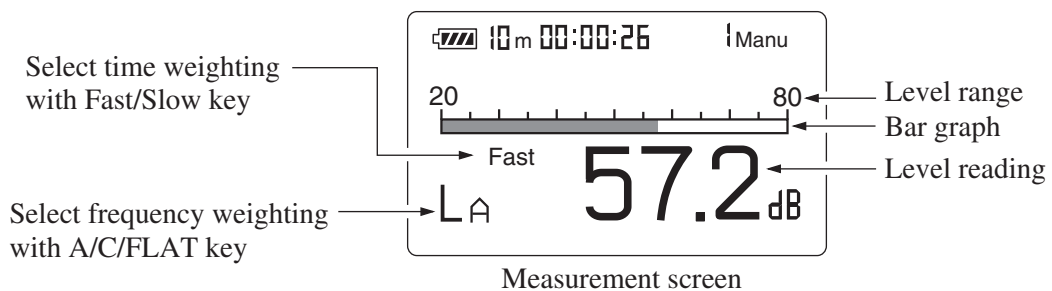

4. Use the Level Range keys to select the level range. Choose a setting in which the bar graph indication registers to about the middle of the range. If the “**Ov**” (Over) or “**Un**” (Under) indicators light up frequently, change the level range setting.

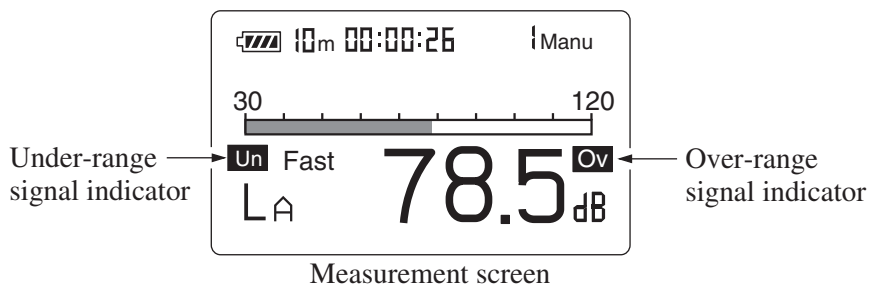

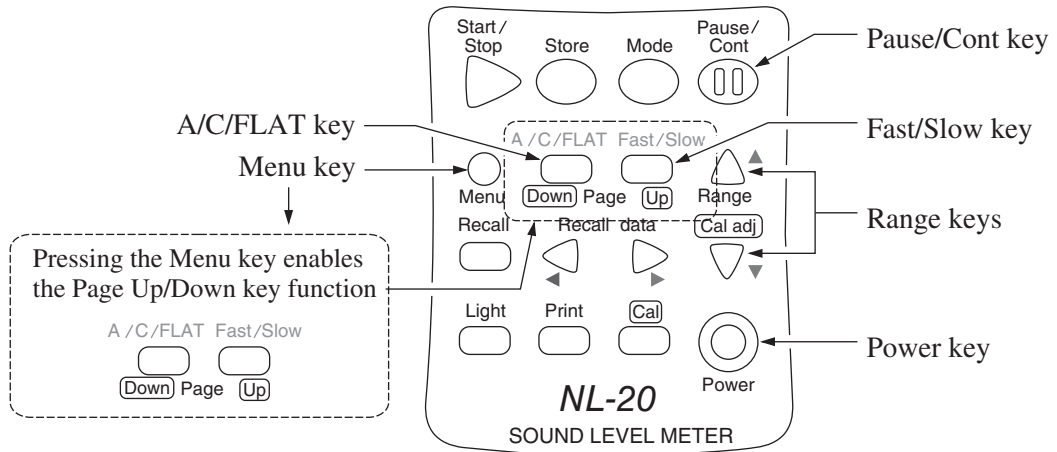

5. Use the menu to set the measurement time.

Press the Menu key to call up the menu screen 1/3.

6. Use the ▲ and ▼ keys to move the cursor to the “Meas. time” item, and use the ◀ and ▶ keys to select the measurement time.

Manual → 10 sec → 1 min → 5 min → 10 min → 15 min → 30 min
→ 1 hour → 8 hours → 24 hours → Manual → ...

When Manual is selected, the measurement time is controlled by the operator. The maximum time is 200 hours.

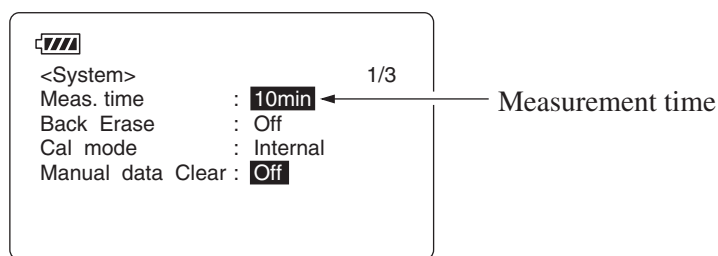

Menu screen 1/3

Important

Because sampling for L_N is performed at 100 ms intervals, a measurement time of 10 seconds or less will not yield correct results.

7. Use the Page Up/Down keys to display the menu screen 2/3.
8. In the default condition, the unit is set up to measure the percentile sound level L_5 , L_{10} , L_{50} , L_{90} , and L_{95} . These settings can be changed to any value between L_1 and L_{99} (up to five settings).
Use the ▲ and ▼ keys to move the highlight and use the ◀ and ▶ keys to change the time percentile number and to toggle the setting between “On” and “Off”.

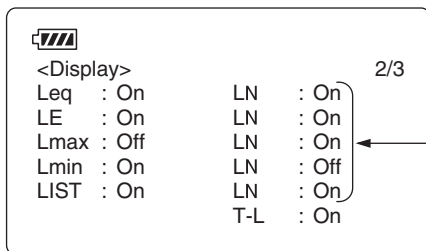

Menu screen 2/3

L_N : Percentile sound level
Set required L_N to On.

L_N can be set in the range from 1 to 99.

Important

Establish these settings before starting the measurement. If a setting is changed later, the measurement will be invalid.

9. To use the data exclusion (back-erase) function, please refer to page 62.

Note

In addition to the regular pause function it is also possible to exclude (back-erase) data from the immediately preceding 5 seconds.

10. Press the Menu key to return to the measurement screen.

11. Press the Start/Stop key to start the measurement.
During measurement, the ► symbol flashes and the elapsed measurement time is displayed.

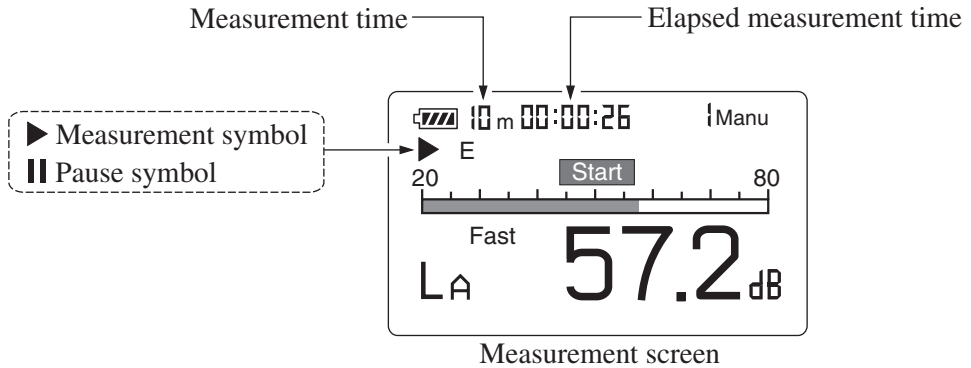

When the measurement time set in step 6 has elapsed, the measurement terminates automatically. When wishing to terminate the measurement earlier, press the Start/Stop key.

If no display (arbitrary measurement time) was selected, the Start/Stop key must be used to conclude the measurement.

If an over-range or under-range condition has occurred at least once during the measurement, the “**Un**” (Under) or “**Ov**” (Over) indication is shown on the display, to indicate that over-range or under-range data were included in the sound level measurement values used for processing.

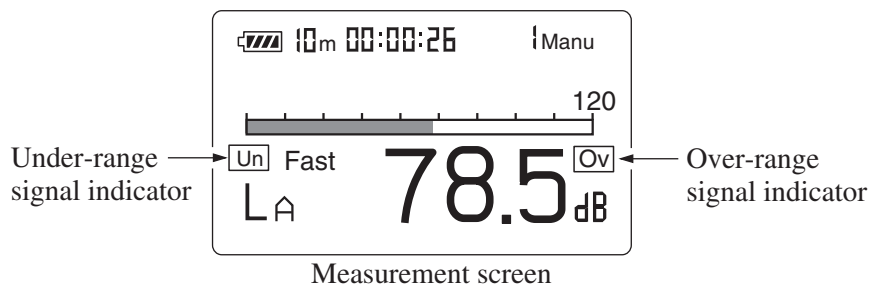

Important

During measurement, most of the keys such as the A/C/FLAT key and Level keys are in-operative. Only the following four keys can be used: Start/Stop, Pause/Cont, Mode, Light. All other settings must be made before starting the measurement.

During measurement, the Pause/Cont key can be used to pause and resume the measurement. During pause, the pause symbol (⏸) is shown. (Any pause intervals and the back-erase time if data back-erase is enabled are not included in the measurement time.)

If data back-erase was enabled in step 9, the data are indicated on the display, as shown below.

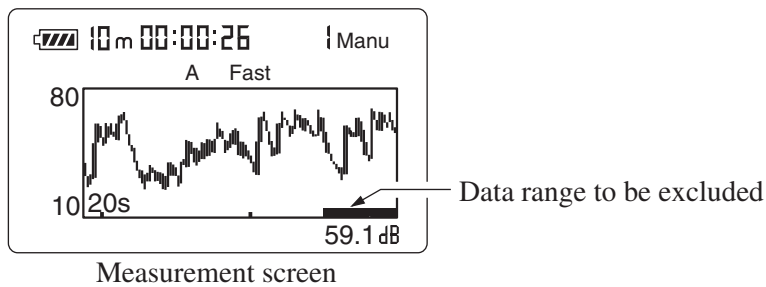

Measurement screen

- When the measurement is completed, you can use the Mode key to switch between various ways of displaying the measurement result. You can display the percentile sound levels selected in step 8, either sequentially or simultaneously.

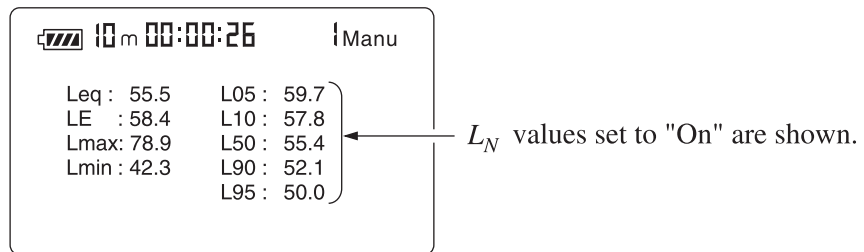

List screen

Note

It is also possible to use the Mode key during measurement to read the percentile sound level up to that point. (This applies only to the numeric level display. The bar graph indication shows the sound level.)

Changing the A/C/FLAT or Fast/Slow setting after measurement is completed has no effect on the displayed processing result.

Back-Erase Function

When a measurement is being carried out and data are being processed, the Pause/Cont key can be used to pause the measurement (i.e. to exclude data from the point at which the key has been pressed), but it is also possible to exclude (back-erase) data from an interval of 5 seconds before the key was pressed. The data that are to be excluded are shown at the bottom of the measurement screen.

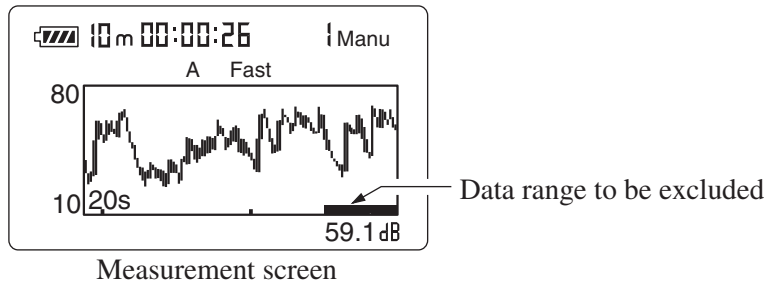

To enable the back-erase function, proceed as follows.

1. Press the Menu key to display the menu screen 1/3.

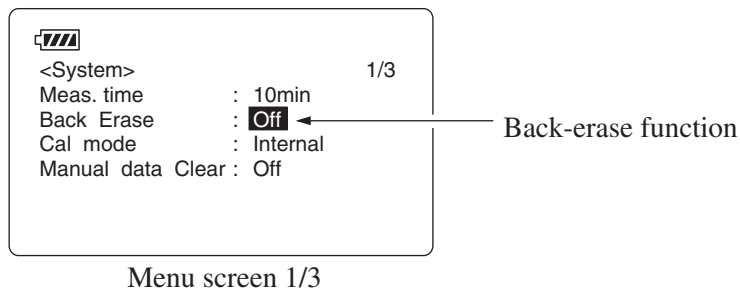

2. Use the ▲ and ▼ keys to move the highlight to the “Back Erase: Off” item.
3. Use the ◀ and ▶ keys to change the setting from “Off” to “5sec”. Press the menu key to return to the measurement screen. The indication “E” is shown on the display, indicating that the data back-erase function has been enabled.

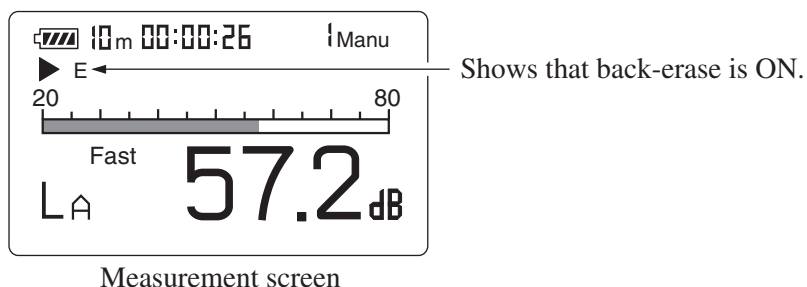

Store Operations

The NL-20 incorporates a memory which can be used to store measurement data (sound level, L_{eq} and other processed values, measurement parameters such as frequency weighting, time weighting, etc.).

This chapter describes how to store data in memory and how to recall data from memory.

Storing Data in Memory

At the point where you press the Store key, the current sound level and all processed values are saved. Immediately after turning the unit on, no processing results exist. Therefore only the sound level gets stored.

The procedure for storing is as follows.

1. Turn the unit on.
2. Select the data number for the store process.

You can use the ◀ and ▶ keys to set the data number to a value between 1 to 100.

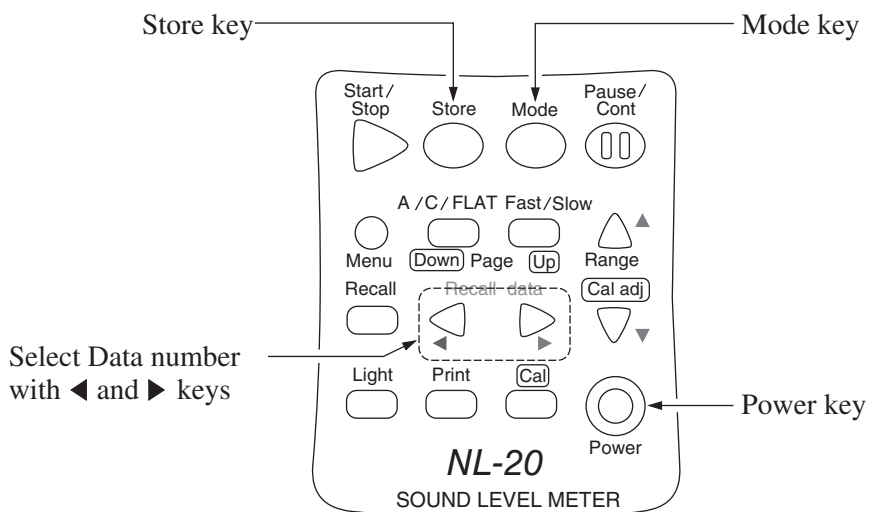

3. Press the Mode key and verify that no processing data exist for the various items (all processing values are 00.0 dB).

If processing data exist, turn power to the unit off and then on again.

If stored measurement data exist, the earlier data will be overwritten by the new data. For information on how to check for stored data, please refer to the section “Reading Stored Data” on page 66.

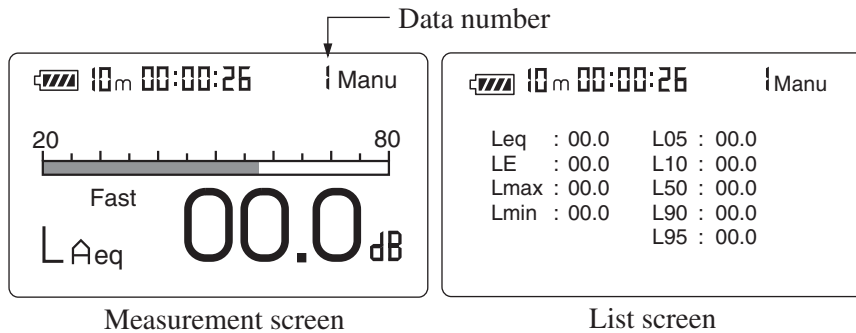

Use the Mode key to switch between screens and verify that all processing values are 00.0 dB

Important

Do not turn power to the unit off during the store process. Otherwise internal data may be damaged.

4. To store processed values, perform the measurement as described in the preceding chapter (except for “Sound level Measurement”).

5. Press the Store key.

The sound level at point when the key was pressed is stored.

The store process is completed in about one second, and the data number is incremented by 1. Pressing the Store key repeatedly allows you to consecutively store data.

The stored data comprise all information shown on the display (except for the battery indication), as well as the current date and time, start date and time of processing, measurement time, frequency weighting, time weighting, and processing results.

The time/level graph shown on the display is not stored.

| Important |
|--|
| The unit does not check whether data to be stored are present. When the Store key is pressed, the data in the currently selected data number are overwritten, even if no new data are available. |

| Note |
|---|
| When the data number 100 is reached, the indication does not change further and does not return to 1. When the Store key is pressed in this condition, the "100" indication flashes, but data are not stored. Pressing the ▲ and ▼ (Data No.) keys to select another number causes the indication to stop flashing, and data can be stored in the selected data number. |

Reading Stored Data

To read data stored, proceed as follows.

1. Turn the unit on.
2. Press the Recall key.
The recall screen appears.
3. Use the Recall Data ◀ and ▶ keys to select the data number in which the data were stored. The data are shown on the display.
When there are no data in a number, the display only shows "--.-".
Press the Mode key to switch between the stored sound level data and the various processing results.

| Important |
|--|
| When wishing to check whether data are present in a data number, use the Mode key to switch the display to sound level and then verify whether data or "--.-" is shown on the display. If "--.-" is shown in other mode settings, that data number may still contain sound level data. |

4. To terminate the recall mode, press the Recall key once more.

Clearing Stored Data

To clear data stored in manual mode, proceed as follows.

1. Press the Menu key to call up the menu screen 1/3.
2. Set the “Manual data clear” item to “On”.

To clear (erase) the data, press the Start key. The manual data are cleared, and the unit returns to menu screen 1/3 with the “Manual data clear” item set to “Off”.

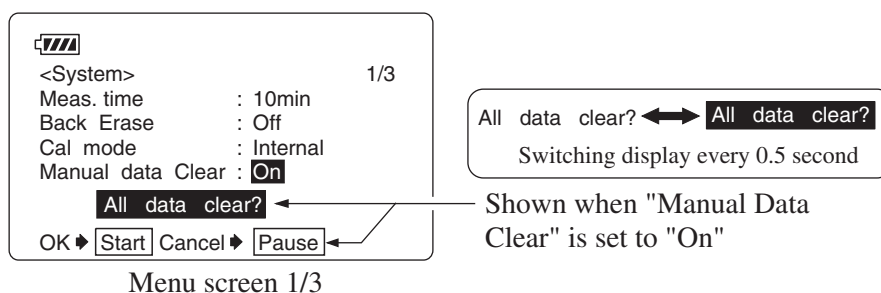

Default Settings

The factory default settings of the unit are listed below.

| | |
|----------------------------------|-----------|
| Fast/Slow (time weighting) | Fast |
| A/C/FLAT (frequency weighting) | A |
| Level Range | 30 to 120 |
| Mode | L_p |
| Meas. Time | 10 min |
| Back Erase | Off |
| LCD Contrast | *****-- |
| I/O Baud Rate | 19200 bps |
| Index | 1 |
| Output AC/DC | AC |
| Light Auto Off | 5 min |
| L_{eq} | On |
| L_{50} | On |
| L_E | Off |
| $L_{05}, L_{10}, L_{90}, L_{95}$ | Off |
| L_{max}, L_{min} | Off |
| LIST, T-L | On |

When you turn power to the unit on while holding down the Start/Stop key, the unit will be initialized to the above settings.

Output Connectors

AC Output

An AC signal corresponding to the frequency-weighted signal is output.

| | |
|-------------------|--|
| Output voltage: | 1 Vrms \pm 50 mV rms (scale upper limit) |
| Output impedance: | approx. 600 Ω |
| Load impedance: | 10 k Ω or higher |
| Suitable cable: | BNC-to-RCA cable CC-24 (option) |

The relationship between unit reading and output voltage is as follows.

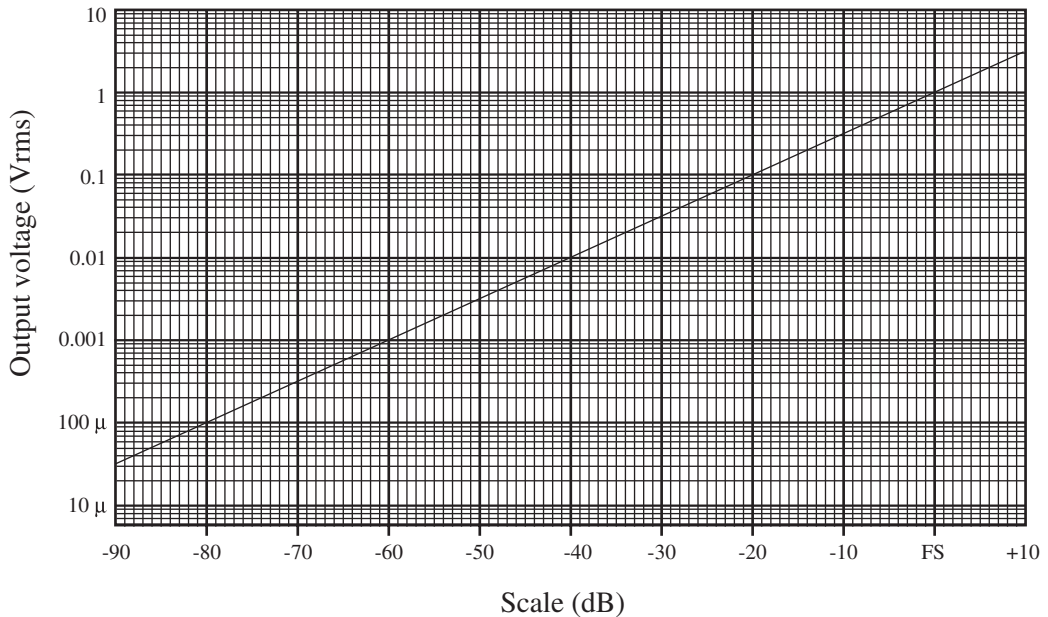

FS : Full-scale value

The output voltage when the unit is in calibration mode (-6 dB from scale upper limit, 1000 Hz sinusoidal wave) is 0.5 Vrms.

To use the AC output, set the item “Output AC/DC” on menu screen 3/3 to “AC”.

DC Output

A level-converted DC signal generated by rms detection and logarithmic compression is output. The signal reflects the frequency weighting and time weighting settings of the unit.

Output voltage: 2.5 V \pm 25 mV (scale upper limit), 0.25 V / 10 dB

Output impedance: approx. 50 Ω

Load impedance: 10 k Ω or higher

Suitable cable: BNC-to-RCA cable CC-24 (option)

The relationship between unit reading and output voltage is as follows.

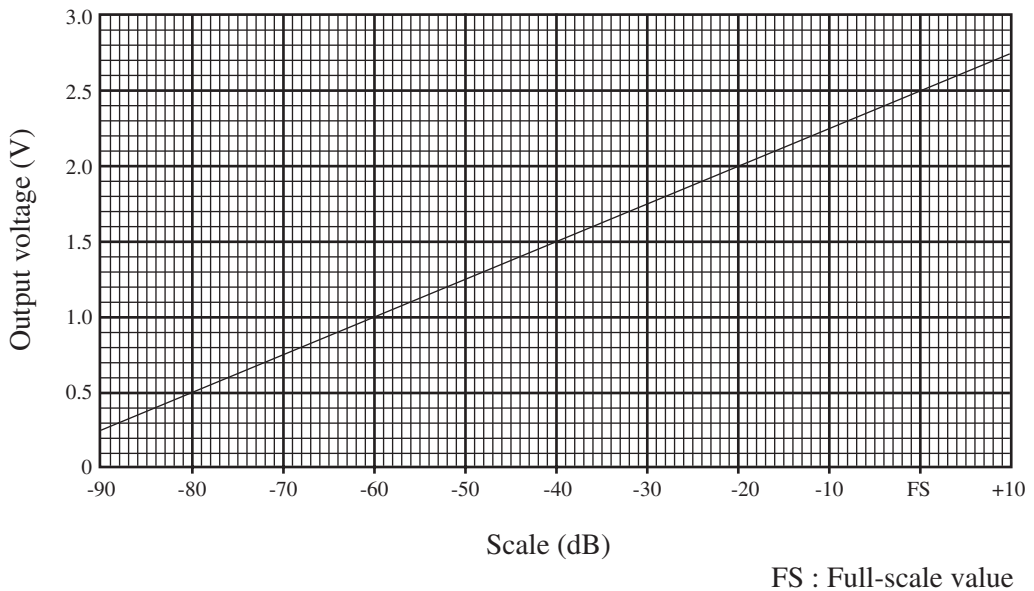

The output voltage when the unit is in calibration mode (-6 dB from scale upper limit) is 2.35 V.

To use the DC output, set the item “Output AC/DC” on menu screen 3/3 to “DC”.

I/O Connector

This input/output connector serves for input of control signals and input/output of measurement data.

The following types of cable can be connected.

- Printer cable CC-93
For data output to printer DPU-414, CP-10, CP-11
- Interface cable CC-92
For communication with a computer

Optional Accessories

Microphone Extension Cables EC-04 Series

For measurements requiring special precision, the microphone can be removed from the main unit and connected by means of an extension cable. This reduces measurement deviations due to refraction effects and the acoustic influence of the operator.

As shown in the table below, six types of cables with a length of 2 to 100 meters are optional. It is also possible to connect several cables in series.

Extension cable EC-04 series

| Model | Length | Model | Length |
|--------|--------|--------|---------------------------------------|
| EC-04 | 2 m | EC-04C | 30 m (reel) + 5 m (connection cable) |
| EC-04A | 5 m | EC-04D | 50 m (reel) + 5 m (connection cable) |
| EC-04B | 10 m | EC-04E | 100 m (reel) + 5 m (connection cable) |

Important

With long extension cables, the cable capacitance restricts the upper measurement frequency and measurement level. For details, please refer to the Technical Notes.

Printer DPU-414/CP-11/CP-10

Measurement data shown on the display, as well as data stored in the memory of the unit can be printed out on a connected printer.

The procedure for printing is described below. Before starting, connect the printer to the NL-20, turn both units on, and set the printer to the on-line condition. Preparations as described in the chapter “Preparations” (page 9) should also be completed.

Printing out measurement parameters

The contents of the display can be printed out.

1. Press the Menu key to call up the menu screen.
2. Use the Page Up/Down keys to select the page you want to print out (1/3 to 3/3).

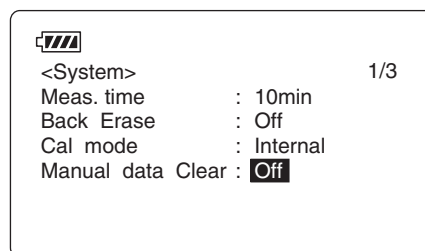
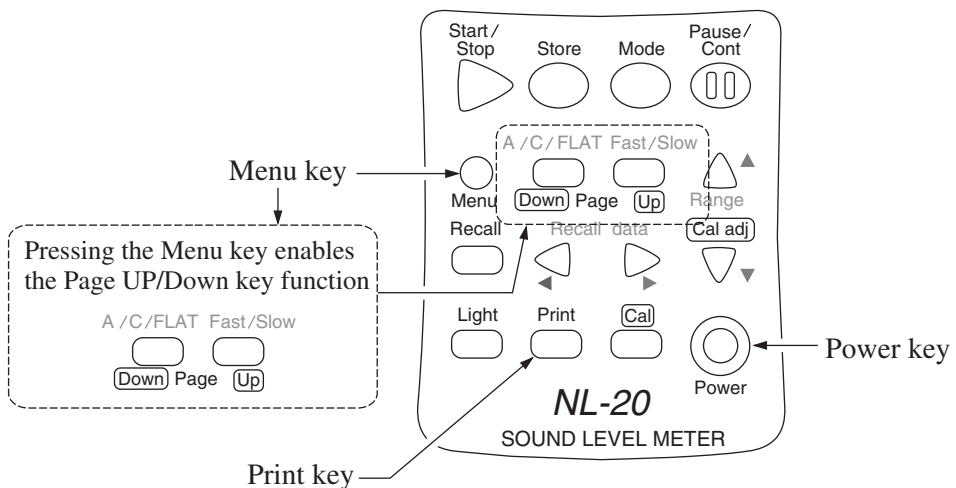

Menu screen example

Menu screen 1/3

3. Press the Print key.

Sample printout

```
<Measurement>      1/3  
Meas. time         : 10 min  
Back Erase        : Off  
<Memory>  
Manual data Clear : Off
```

Sample printout

Actual font and size will be different.

Printing out data during a measurement (sound level display)

A hard copy of the screen is printed out.

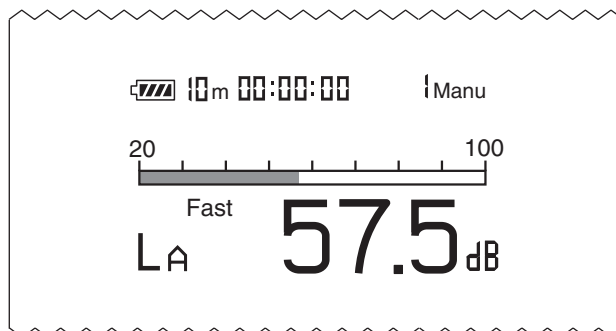

Sample printout

Printing out data stored with manual mode in the internal memory

The following explanation assumes that data have been stored in the memory of the unit.

To print out the data, proceed as follows.

1. Press the Recall key to call up the menu screen on the display.
2. Use the ◀ and ▶ (Data No.) keys to select the data for printout.
3. Press the Print key.

The printout contents will vary, depending on the contents (sound level or processed values) shown on the display.

- When processed values are displayed

Example

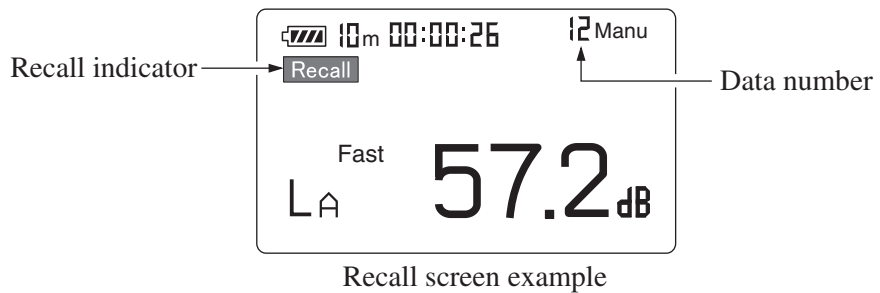

4. To terminate the recall mode, press the Recall key again.

Level Recorder LR-06/LR-07/LR-04/LR-20A

For continuous recording of noise level changes, a level recorder can be connected to the unit.

Sound level recording

The procedure for noise level recording on a level recorder is described below. Before starting, connect the level recorder to the NL-20 and turn power on. Preparations as described in the chapter “Preparations” (page 9) must also be completed. For details regarding use of the level recorder, please refer to its documentation.

1. Call up the menu screen 1/3 and verify that the “Cal Mode” item is set to “Internal”. If “External” is shown, use the ▲ and ▼ keys to move the cursor to “External” and use the ◀ and ▶ keys to set it to “Internal”.

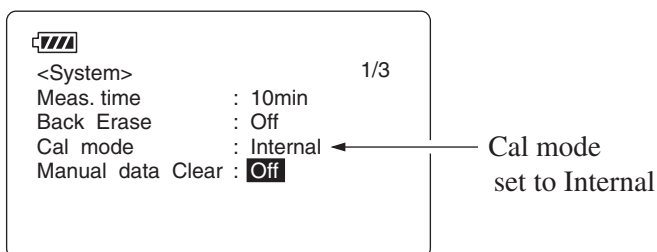

Menu screen 1/3

2. Call up the menu screen 3/3 and set the “Output AC/DC” item to “AC”.

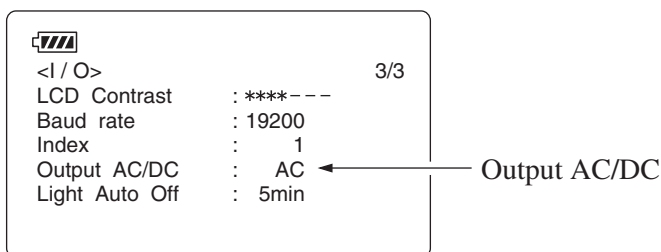

Menu screen 3/3

When the setting is complete, press the Menu key to return to the measurement screen.

3. Press the Cal key to set the unit to the calibration mode.
4. Activate the paper feed and pen operation of the level recorder to start recording.

- Adjust the level control (Level adj) of the level recorder so that the pen is at a point -6 dB below the full-scale point.

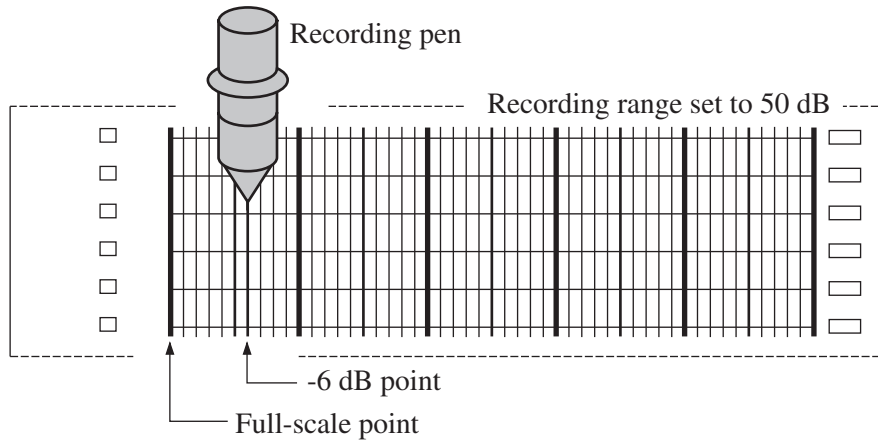

- Press the Cal key once more to return to the measurement mode.
- Use the A/C/FLAT key to set the frequency weighting. The time weighting is adjusted at the level recorder.
- Use the Level Range keys to select the level range. Choose a setting in which the "Over" or "Under" indication does not appear. The upper limit of the level range selected at the NL-20 becomes the full-scale point of the level recorder.

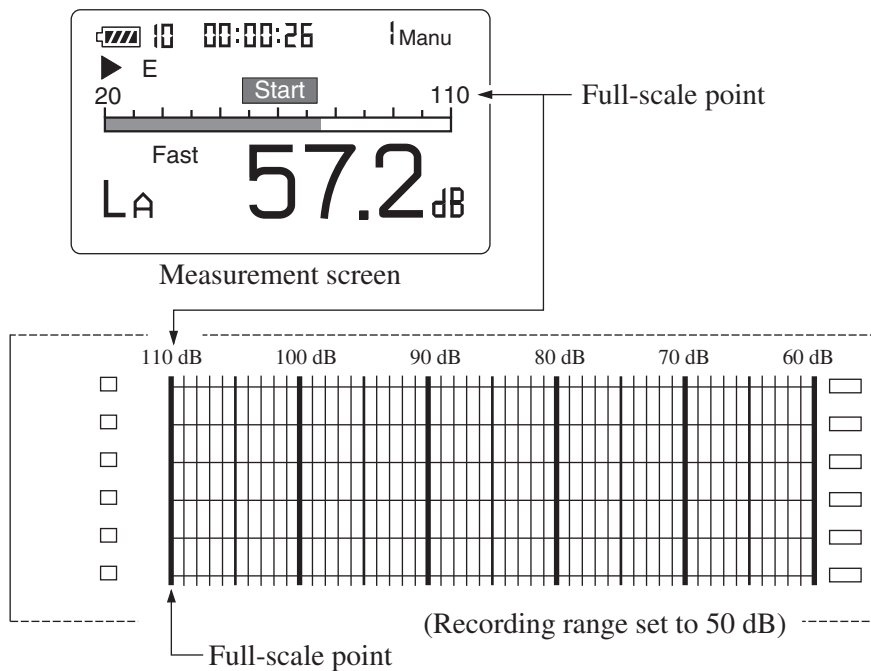

Specifications

Applicable standards

IEC 61672-1:2002 Class 2

JIS C 1509-1:2005 Class 2

IEC 60651 and IEC 60804 was withdrawn and replaced by IEC 61672-1:2002.

JIS C 1502 was withdrawn and replaced by JIS C 1509-1.

Measurement functions

Main processing functions

Simultaneous measurement of all items according to selected time weighting and frequency weighting

Sound level L_p

Equivalent continuous sound level L_{eq}

Sound exposure level L_E

Maximum sound level L_{max}

Minimum sound level L_{min}

Percentile sound level L_N (5 selectable settings)

Measurement time

10 seconds, 1, 5, 10, 15, 30 minutes, 1, 8, 24 hours, and manual (maximum 200 hours)

Total range 28 to 138 dB

Max. measurement level

138 dB

Noise floor A weighting: 22 dB or less
 C weighting: 27 dB or less
 Flat: 32 dB or less

| | |
|---|--|
| Linearity range | 100 dB |
| Reference sound pressure level | 94 dB |
| Reference level range | 30 to 120 dB |
| Calibration check frequency | 1 kHz |
| Level range selection | |
| 6 ranges in 10-dB steps | 20 to 80 dB |
| | 20 to 90 dB |
| | 20 to 100 dB |
| | 20 to 110 dB |
| | 30 to 120 dB |
| | 40 to 130 dB |
| Frequency range | |
| Overall characteristics including microphone: | 20 to 8000 Hz |
| Electrical circuit characteristics (AC output): | 10 to 20000 Hz |
| Electrical circuit characteristics (detector): | 10 to 14000 Hz |
| Frequency weighting | |
| | A, C, FLAT |
| RMS detection | Digital processor |
| | Characteristics: Fast, Slow |
| Calibration | |
| | Electrical calibration with 1-kHz sinusoidal wave signal from built-in oscillator |
| | Calibration using sound calibrator |
| Back-erase function | Pause key can be set to erase data from preceding 5 seconds |
| Processing functions | |
| Digital processing | |
| | Sampling interval |
| | 30.3 μ s (L_{eq} , L_E) |
| | 100 ms (L_N) |
| Data store functions | Data can be stored in the internal memory. |
| | Max. 100 data sets for L_p , L_{eq} , L_E , L_{max} , L_{min} , L_N can be stored. |

Microphone

1/2-inch electret condenser type

Model: UC-52

Sensitivity: -33 dB

Preamplifier

NH-21

Display

Backlit LCD (128 × 64 dots + 121 icons)

Display screens

Numeric and bar graph indication of sound level

Processing results screen

Level-time graph (real-time level recording with 20-second horizontal axis)

Menu screens for operation settings

Warning indications

Over-range indication: full-scale +8.5 dB

Under-range indication: full-scale -2.6 dB

Outputs

AC/DC output

Key-selectable AC or DC output

AC output (using selected frequency weighting)

Output voltage: 1 V_{rms} (at full-scale)

Output impedance: 600 Ω

Load impedance: 10 kΩ or more

DC output

Output voltage: 2.5 V (at full-scale),

0.25 V/10 dB

Output impedance: 50 Ω

Load impedance: 10 kΩ or more

| | |
|---------------|--|
| I/O connector | Sound level meter control from and data output to a computer |
| | Data output to printer DPU-414 /CP-11/CP-10 |
| | Transfer principle |
| | Transfer principle: asynchronous |
| | Data word length: 8 bit |
| | Stop bits: 1 |
| | Parity check: none |
| | Baud rate: 4800, 9600, 19200 (bps) |
| | Flow control: yes |
| | Select X parameter control or RTS/CTS control |

Power requirements

Four IEC R6 (size “AA”) batteries

Battery life (23°C)

Approx. 34 h (alkaline batteries LR6),

Approx. 14 h (manganese batteries R6P)

With backlighting, battery life is reduced to about half.

When auxiliary processing functions are enabled, battery life is reduced by about 20%.

When the optional filter is enabled, battery life is reduced by about 15%.

AC adapter (option)

NC-34: 100 V AC

NC-34A: 120 V AC

NC-34B: 220 V AC

NC-98A: 100 to 240 V AC (CE-marked)

NC-98B: 100 to 240 V AC (CE-marked)

Current rating (when 6 V DC is input)

Approx. 50 mA

Ambient conditions

-10°C to +50°C, 10% to 90% RH (no condensation)

Dimensions

Approx. 260 × 76 × 33 mm

Weight (including batteries)

Approx. 400 g

Supplied accessories

| | | |
|-----------------------------------|---------|-------|
| Windscreen | WS-10 | 1 |
| Carrying case | | 1 |
| Connector cover (mounted on unit) | | 1 |
| Hand strap | | 1 |
| Batteries | IEC R6P | 4 |
| Product name label | | 1 |
| Logo label | | 1 |
| Inspection certificate | | 1 |
| Instruction manuals | | 1 set |

(Instruction Manual, Technical Notes, Serial Interface Manual, 1 each)

Optional equipment

| | |
|----------------------------|--|
| AC adapter | NC-34 series |
| AC adapter with CE mark | NC-98A (100 to 240 V AC, 50 /60 Hz) NC-98B (100 to 240 V AC, 50 /60 Hz) |
| BNC-to-RCA cable | CC-24 |
| Microphone extension cable | EC-04 series |
| Serial I/O cable | CC-92 |
| Printer cable | CC-93 |
| Printer | DPU-414 |
| Sound calibrator | NC-74 |
| Pistonphone | NC-72A |
| Level recorder | LR-07/LR-20A |

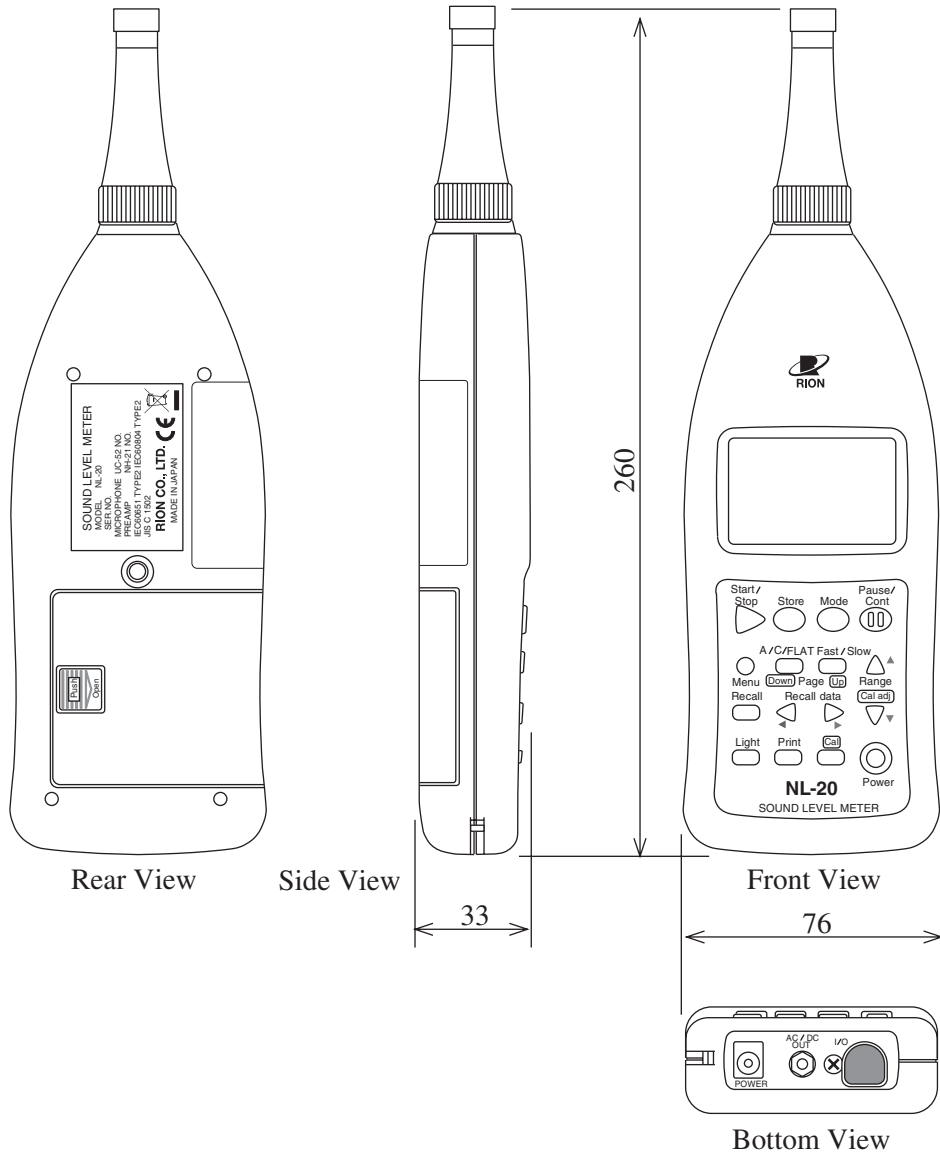

Unit: mm

Dimensional Drawings

